

If the outboard motor's serial number plate contains the CE mark in the lower left-hand corner, the following statement applies:

This outboard motor manufactured by Mercury Marine, Fond du Lac, Wisconsin, USA or Marine Power Europe Inc. Park Industriel, de Petit-Rechain, Belgium complies with the requirements of the following directives and standards, as amended:

Recreational Craft Directive: 94/25/EC; std. ISO 8665,  
ISO 11547

Machinery Directive: 98/37/EC,  
EMC Directive: 89/336/EC; std. EN50081-1,  
SAE J551 (CISPR Pub. 12),  
EN 50082-1, IEC 61000 PT4-2,  
IEC 61000 PT4-3



Patrick C. Mackey

President, Mercury Marine, Fond du Lac, WI USA

European Regulations Contact:  
Product Environmental Engineering Department, Mercury Marine,  
Fond du Lac, WI USA

## Thank You

For your purchase of one of the finest outboards available. You have made a sound investment in boating pleasure. Your outboard has been manufactured by Mercury Marine, a world leader in marine technology and outboard manufacturing since 1939. These years of experience have been committed to the goal of producing the finest quality products. This led to Mercury Marine's reputation for strict quality control, excellence, durability, lasting performance and being the best at providing after-the-sale support.

Please read this manual carefully before operating your outboard. This manual has been prepared to assist you in the operation, safe use and care of your outboard.

All of us at Mercury Marine took pride in building your outboard and wish you many years of happy and safe boating.

Again, thank you for your confidence in Mercury Marine.

## Warranty Message

The product you have purchased comes with a **limited warranty** from Mercury Marine, the terms of the warranty are set forth in the *Warranty Information* Section of this manual. The warranty statement contains a description of what is covered, what is not covered, the duration of coverage, how to best obtain warranty coverage, **important disclaimers and limitations of damages**, and other related information. Please review this important information.

# TABLE OF CONTENTS

## Warranty Information

Transfer of Warranty .....	5
Warranty Registration	
United States and Canada .....	6
Outside United States and Canada .....	7
Outboard Limited Warranty .....	8
3 Year Limited Warranty against Corrosion .....	10
Warranty Coverage and Exclusions .....	12

## General Information

Boater's Responsibilities .....	14
Before Operating Your Outboard .....	15
Boat Horsepower Capacity .....	16
Outboard Remote Control .....	17
Remote Steering Notice .....	17
Lanyard Stop Switch .....	18
Stopping The Boat In an Emergency .....	20
Protecting People In The Water .....	21
Wave and Wake Jumping .....	22
Exhaust Emissions .....	23
Selecting Accessories For Your Outboard .....	25
Safe Boating Suggestions .....	25
Recording Serial Number .....	28
Specifications .....	29
Component Identification .....	30

# TABLE OF CONTENTS

## Installation

Installing Outboard ..... 31

## Transporting

Trailer Boat/Outboard ..... 32

## Fuel & Oil

Gasoline Recommendations ..... 33  
 Oil Recommendation ..... 34  
 New Engine Gasoline/Oil Break-In Mixture ..... 34  
 Mixing Fuel and Oil ..... 34  
 Filling Oil Injection System ..... 35  
 Filling Fuel Tank ..... 36

## Features & Controls

Remote Control Features ..... 37  
 Warning System ..... 38  
 Power Trim and Tilt ..... 40  
 Replaceable Jet Drive Shear Key ..... 42

# TABLE OF CONTENTS

## Operation

Pre-Starting Check List . . . . .	43
How the Jet Drive Operates . . . . .	44
Stopping the Boat in an Emergency . . . . .	45
Steering Your Boat . . . . .	46
Operating in Shallow Water . . . . .	47
Water Intake Blockage . . . . .	47
Clearing a Jammed Impeller . . . . .	48
Mooring Your Boat . . . . .	48
Operating in Freezing Temperature . . . . .	48
Operating at High Elevations . . . . .	49
Operating in Salt Water or Polluted Water . . . . .	49
Engine Break-In Procedure . . . . .	50
Starting The Engine . . . . .	51
Gear Shifting . . . . .	54
Stopping The Engine . . . . .	54
Emergency Starting . . . . .	55

## Maintenance

Outboard Care . . . . .	57
Selecting Replacement Parts For Your Outboard . . . . .	57
Inspection and Maintenance Schedule . . . . .	59
Flushing the Cooling System . . . . .	61
Top Cowl Removal and Installation . . . . .	62
Battery Inspection . . . . .	62
Fuel System . . . . .	63
Steering Link Rod Fasteners . . . . .	64
Fuse Replacement . . . . .	65
Corrosion Control Anode . . . . .	65
Spark Plug Inspection and Replacement . . . . .	66
Steering Pull Adjustment . . . . .	67
Worn (Dull) Impeller . . . . .	68
Impeller Clearance Adjustment . . . . .	69
Impeller Removal and Installation . . . . .	70
Lubrication Points . . . . .	73
Checking Power Trim Fluid . . . . .	75
Submerged Outboard . . . . .	75

# TABLE OF CONTENTS

## Storage

Storage Preparation .....	76
---------------------------	----

## Troubleshooting

Troubleshooting .....	79
-----------------------	----

## Owner Service Assistance

Local Repair Service .....	81
Service Away From Home .....	81
Parts and Accessories Inquiries .....	81
Service Assistance .....	82
Mercury Marine Service Offices .....	83

## Maintenance Log

Maintenance Log .....	84
-----------------------	----

The description and specifications contained herein were in effect at the time this manual was approved for printing. Mercury Marine, whose policy is one of continued improvement, reserves the right to discontinue models at any time, to change specifications, designs, methods, or procedures without notice and without incurring obligation.

Mercury Marine, Fond du Lac, Wisconsin U.S.A.      Litho in U.S.A.

© 2003, Mercury Marine

The following are registered trademarks of Brunswick Corporation: AutoBlend, Force, Jet-Prop, Mariner, Merc, MerCathode, MerCruiser, Mercury, Mercury Marine, Quicksilver, RideGuide and Thruster.

# WARRANTY INFORMATION

oq2

## Transfer Of Warranty

The limited warranty is transferable to a subsequent purchaser, but only for the remainder of the unused portion of the limited warranty. This will not apply to products used for commercial applications.

### **DIRECT SALE BY OWNER**

The second owner can be registered as the new owner and retain the unused portion of the limited warranty by sending the former owner's plastic Owner Warranty Registration Card and a copy of the bill of sale to show proof of ownership. In the United States and Canada, mail to:

Mercury Marine  
W6250 W. Pioneer Road  
P.O. Box 1939  
Fond du Lac, WI 54936-1939  
Attn: Warranty Registration Department

A new Owner Warranty Registration Card will be issued with the new owner's name and address. Registration records will be changed on the factory computer registration file.

There is no charge for this service.

For products purchased outside the United States and Canada, contact the distributor in your country, or the Mercury Marine Service Office closest to you.

# WARRANTY INFORMATION

ou1

## Warranty Registration

### UNITED STATES AND CANADA

1. It is important that your selling dealer fills out the Warranty Registration Card completely and mails it to the factory immediately upon sale of the new product.
2. It identifies name and address of the original purchaser, product model and serial number(s), date of sale, type of use and selling dealer's code, name and address. The dealer also certifies that you are the original purchaser and user of the product.
3. Upon receipt of the Warranty Registration Card at the factory, you will be issued a plastic Owner Warranty Registration Card which is your only valid registration identification. It must be presented to the servicing dealer should warranty service be required. Warranty claims will not be accepted without presentation of this card.
4. A temporary Owner Warranty Registration Card will be presented to you when you purchase the product. It is valid only for 30 days from date of sale while your plastic Owner Warranty Registration Card is being processed. Should your product need service during this period, present the temporary registration card to the dealer. He will attach it to your warranty claim form.
5. Because of your selling dealer's continuing personal interest in your satisfaction, the product should be returned to him for warranty service.
6. If your plastic card is not received within 30 days from date of new product sale, please contact your selling dealer.
7. The product warranty is not effective until the product is registered at the factory.

*NOTE: Registration lists must be maintained by factory and dealer on marine products sold in the United States, should notification under the Federal Boat Safety Act be required.*

# WARRANTY INFORMATION

ou2

## Warranty Registration

### OUTSIDE THE UNITED STATES AND CANADA

1. It is important that your selling dealer fills out the Warranty Registration Card completely and mails it to the distributor or Marine Power Service Center responsible for administering the warranty registration/claim program for your area.
2. The Warranty Registration Card identifies your name and address, product model and serial number(s), date of sale, type of use and the selling distributor's/dealer's code number, name and address. The distributor/dealer also certifies that you are the original purchaser and user of the product.
3. A copy of the Warranty Registration Card, designated as the "Purchaser's Copy", MUST be given to you immediately after the card has been completely filled out by the selling distributor/dealer. This card represents your factory registration identification, and should be retained by you for future use when required. Should you ever require warranty service on this product, your dealer may ask you for the Warranty Registration Card to verify date of purchase and to use the information on the card to prepare the warranty claim form(s).
4. In some countries, the Marine Power Service Center will issue you a permanent (plastic) Warranty Registration Card within 30 days after receiving the "Factory Copy" of the Warranty Registration Card from your distributor/dealer. If you receive a plastic Warranty Registration Card, you may discard the "Purchaser's Copy" that you received from the distributor/dealer when you purchased the product. Ask your distributor/dealer if this plastic card program applies to you.
5. For further information concerning the Warranty Registration Card and its relationship to Warranty Claim processing, refer to the "International Warranty".

**IMPORTANT: Registration lists must be maintained by the factory and dealer in some countries by law. It is our desire to have ALL products registered at the factory should it ever be necessary to contact you. Make sure your dealer/distributor fills out the warranty registration card immediately and sends the factory copy to the Marine Power International Service Center for your area.**

# WARRANTY INFORMATION

ou40

## Mercury Marine Two Years Limited Warranty(Europe)

### WHAT IS COVERED

Mercury Marine warrant each new Mercury Outboard, Mariner Outboard, Jet Products, Thruster Electric Trolling Motors, Mercruiser Inboard or Sterndrive engine products to be free in material and workmanship during the period described below.

### DURATION OF COVERAGE

This Limited Warranty provides coverage for two (2) years from the date the product is first sold to a recreational use retail purchaser, or the date on which the product is first put into service, whichever occurs first. Commercial users of these products receive warranty coverage of two (2) years from the date of first retail sale, or the accumulation of 500 hours of operation, whichever occurs first. Commercial use is defined as any work or employment related use of the product, or any use of the product which generates income, for any part of the warranty period, even if the product is only occasionally used for such purposes. The repair or replacement of parts, or the performance of service under this warranty, does not extend the life of this warranty beyond its original expiration date. Unexpired warranty coverage can be transferred to one recreational use to a subsequent recreational use customer upon proper re-registration of the product.

### CONDITIONS THAT MUST BE MET IN ORDER TO OBTAIN WARRANTY COVERAGE

Warranty coverage is available only to retail customers that purchase from a Dealer authorized by Mercury Marine to distribute the product in the country in which the sale occurred, and then only after the Mercury Marine specified pre-delivery inspection process is completed and documented. Warranty coverage becomes available upon proper registration of the product by the authorized dealer. Inaccurate warranty registration information regarding recreational use, or subsequent change of use from recreational to commercial (unless properly re-registered) may void the warranty at the sole discretion of Mercury Marine. Routine maintenance outlined in the Operation and Maintenance Manual must be timely performed in order to maintain warranty coverage. If this maintenance is performed by the retail customer Mercury Marine reserves the right to make future warranty coverage contingent on proof of proper maintenance.

### WHAT MERCURY WILL DO

Mercury's sole and exclusive obligation under this warranty is limited to, at our option, repairing a defective part, replacing such part or parts with new or Mercury Marine certified re-manufactured parts, or refunding the purchase price of the Mercury product. Mercury reserves the right to improve or modify products from time to time without assuming an obligation to modify products previously manufactured.

## **WARRANTY INFORMATION**

### **Mercury Marine Two Years Limited Warranty(Europe)**

#### **HOW TO OBTAIN WARRANTY COVERAGE**

The customer must provide Mercury with a reasonable opportunity to repair, and reasonable access to the product for warranty service. Warranty claims shall be made by delivering the product for inspection to a Mercury dealer authorized to service the product. If purchaser cannot deliver the product to such a dealer, written notice must be given to Mercury. We will then arrange for the inspection and any covered repair. Purchaser in that case shall pay for all related transportation charges and/or travel time. If the service provided is not covered by this warranty, purchaser shall pay for all related labor and material, and any other expenses associated with that service. Purchaser shall not, unless requested by Mercury, ship the product or parts of the product directly to Mercury. The warranty registration card is the only valid registration identification and must be presented to the dealer at the time warranty service is requested in order to obtain coverage.

## **WARRANTY INFORMATION**

### **Mercury Marine Two Years Limited Warranty(Europe)**

ou24a

#### **WHAT IS NOT COVERED**

This limited warranty does not cover routine maintenance items, tune ups, adjustments, normal wear and tear, damage caused by abuse, abnormal use, use of a propeller or gear ratio that does not allow the engine to run in its recommended wide-open-throttle RPM range (see the Operation and Maintenance Manual), operation of the product in a manner inconsistent with the recommended operation/duty cycle section of the Operation and Maintenance Manual, neglect, accident, submersion, improper installation (proper installation specifications and techniques are set forth in the installation instructions for the product), improper service, use of an accessory or part not manufactured or sold by us, jet pump impellers and liners, operation with fuels, oils or lubricants which are not suitable for use with the product (see the Operation and Maintenance Manual), alteration or removal of parts, or water entering the engine through the fuel intake, air intake or exhaust system. Use of the product for racing or other competitive activity, or operating with a racing type lower unit, at any point, even by a prior owner of the product, voids the warranty.

Expenses related to haul-out, launch, towing, storage, telephone, rental, inconvenience, slip fees, insurance coverage, loan payments, loss of time, loss of income, or any other type of incidental or consequential damages are not covered by this warranty. Also, expenses associated with the removal and/or replacement of boat partitions or material caused by boat design for access to the product are not covered by this warranty.

## **WARRANTY INFORMATION**

### **Mercury Marine Two Years Limited Warranty(Europe)**

No individual or entity, including Mercury Marine authorized dealers, has been given authority by Mercury Marine to make any affirmation, representation or warranty regarding the product, other than those contained in this limited warranty, and if made, shall not be enforceable against Mercury Marine.

For additional information regarding events and circumstances covered by this warranty, and those that are not, see the Warranty Coverage section of the Operation and Maintenance Manual, incorporated by reference into this warranty.

#### **DISCLAIMERS AND LIMITATIONS:**

**THE IMPLIED WARRANTIES OF MERCHANTABILITY AND FITNESS FOR A PARTICULAR PURPOSE ARE EXPRESSLY DISCLAIMED. TO THE EXTENT THAT THEY CANNOT BE DISCLAIMED, THE IMPLIED WARRANTIES ARE LIMITED IN DURATION TO THE LIFE OF THE EXPRESS WARRANTY. INCIDENTAL AND CONSEQUENTIAL DAMAGES ARE EXCLUDED FROM COVERAGE UNDER THIS WARRANTY. SOME STATES/COUNTRIES DO NOT ALLOW FOR THE DISCLAIMERS, LIMITATIONS AND EXCLUSIONS IDENTIFIED ABOVE, AS A RESULT, THEY MAY NOT APPLY TO YOU. THIS WARRANTY GIVES YOU SPECIFIC LEGAL RIGHTS, AND YOU MAY ALSO HAVE OTHER LEGAL RIGHTS WHICH VARY FROM STATE TO STATE AND COUNTRY TO COUNTRY.**

# **WARRANTY INFORMATION**

## **Mercury Marine ONE Year Limited**

### **Warranty(Confederation of Independent States, Middle–East, Africa)**

#### **WHAT IS COVERED**

Mercury Marine warrant each new Mercury outboard, Mariner outboard, Jet Products, Thruster Electric Trolling Motors, Mercruiser Inboard or Sterndrive engine products to be free in material and workmanship during the period described below.

#### **DURATION OF COVERAGE**

This Limited Warranty provides coverage for one (1) year from the date the product is first sold to a recreational use retail purchaser, or the date on which the product is first put into service, whichever occurs first. Commercial users of these products receive warranty coverage of one (1) years from the date of first retail sale, or the accumulation of 500 hours of operation, whichever occurs first. Commercial use is defined as any work or employment related use of the product, or any use of the product which generates income, for any part of the warranty period, even if the product is only occasionally used for such purposes. The repair or replacement of parts, or the performance of service under this warranty, does not extend the life of this warranty beyond its original expiration date. Unexpired warranty coverage can be transferred to a subsequent purchaser upon proper re–registration of the product.

#### **CONDITIONS THAT MUST BE MET IN ORDER TO OBTAIN WARRANTY COVERAGE**

Warranty coverage is available only to retail customers that purchase from a Dealer authorized by Mercury Marine to distribute the product in the country in which the sale occurred, and then only after the Mercury Marine specified pre–delivery inspection process is completed and documented. Warranty coverage becomes available upon proper registration of the product by the authorized dealer. Inaccurate warranty registration information regarding recreational use, or subsequent change of use from recreational to commercial (unless properly re–registered) may void the warranty at the sole discretion of Mercury Marine. Routine maintenance outlined in the Operation and Maintenance Manual must be timely performed in order to maintain warranty coverage. If this maintenance is performed by the retail customer Mercury Marine reserves the right to make future warranty coverage contingent on proof of proper maintenance.

## **WARRANTY INFORMATION**

### **Mercury Marine ONE Year Limited**

### **Warranty(Confederation of Independent States, Middle–East, Africa)**

#### **WHAT MERCURY WILL DO**

Mercury's sole and exclusive obligation under this warranty is limited to, at our option, repairing a defective part, replacing such part or parts with new or Mercury Marine certified re-manufactured parts, or refunding the purchase price of the Mercury product. Mercury reserves the right to improve or modify products from time to time without assuming an obligation to modify products previously manufactured.

#### **HOW TO OBTAIN WARRANTY COVERAGE**

The customer must provide Mercury with a reasonable opportunity to repair, and reasonable access to the product for warranty service. Warranty claims shall be made by delivering the product for inspection to a Mercury dealer authorized to service the product. If purchaser cannot deliver the product to such a dealer, written notice must be given to Mercury. We will then arrange for the inspection and any covered repair. Purchaser in that case shall pay for all related transportation charges and/or travel time. If the service provided is not covered by this warranty, purchaser shall pay for all related labor and material, and any other expenses associated with that service. Purchaser shall not, unless requested by Mercury, ship the product or parts of the product directly to Mercury. The warranty registration card is the only valid registration identification and must be presented to the dealer at the time warranty service is requested in order to obtain coverage.

## **WARRANTY INFORMATION**

### **Mercury Marine ONE Year Limited**

### **Warranty(Confederation of Independent States, Middle–East, Africa)**

#### **WHAT IS NOT COVERED**

This limited warranty does not cover routine maintenance items, tune ups, adjustments, normal wear and tear, damage caused by abuse, abnormal use, use of a propeller or gear ratio that does not allow the engine to run in its recommended wide-open-throttle RPM range (see the Operation and Maintenance Manual), operation of the product in a manner inconsistent with the recommended operation/duty cycle section of the Operation and Maintenance Manual, neglect, accident, submersion, improper installation (proper installation specifications and techniques are set forth in the installation instructions for the product), improper service, use of an accessory or part not manufactured or sold by us, jet pump impellers and liners, operation with fuels, oils or lubricants which are not suitable for use with the product (see the Operation and Maintenance Manual), alteration or removal of parts, or water entering the engine through the fuel intake, air intake or exhaust system. Use of the product for racing or other competitive activity, or operating with a racing type lower unit, at any point, even by a prior owner of the product, voids the warranty.

Expenses related to haul-out, launch, towing, storage, telephone, rental, inconvenience, slip fees, insurance coverage, loan payments, loss of time, loss of income, or any other type of incidental or consequential damages are not covered by this warranty. Also, expenses associated with the removal and/or replacement of boat partitions or material caused by boat design for access to the product are not covered by this warranty.

## **WARRANTY INFORMATION**

### **Mercury Marine ONE Year Limited**

### **Warranty(Confederation of Independent States, Middle–East, Africa)**

No individual or entity, including Mercury Marine authorized dealers, has been given authority by Mercury Marine to make any affirmation, representation or warranty regarding the product, other than those contained in this limited warranty, and if made, shall not be enforceable against Mercury Marine.

For additional information regarding events and circumstances covered by this warranty, and those that are not, see the Warranty Coverage section of the Operation and Maintenance Manual, incorporated by reference into this warranty.

#### **DISCLAIMERS AND LIMITATIONS:**

**THE IMPLIED WARRANTIES OF MERCHANTABILITY AND FITNESS FOR A PARTICULAR PURPOSE ARE EXPRESSLY DISCLAIMED. TO THE EXTENT THAT THEY CANNOT BE DISCLAIMED, THE IMPLIED WARRANTIES ARE LIMITED IN DURATION TO THE LIFE OF THE EXPRESS WARRANTY. INCIDENTAL AND CONSEQUENTIAL DAMAGES ARE EXCLUDED FROM COVERAGE UNDER THIS WARRANTY. SOME STATES/COUNTRIES DO NOT ALLOW FOR THE DISCLAIMERS, LIMITATIONS AND EXCLUSIONS IDENTIFIED ABOVE, AS A RESULT, THEY MAY NOT APPLY TO YOU. THIS WARRANTY GIVES YOU SPECIFIC LEGAL RIGHTS, AND YOU MAY ALSO HAVE OTHER LEGAL RIGHTS WHICH VARY FROM STATE TO STATE AND COUNTRY TO COUNTRY.**

# WARRANTY INFORMATION

ou51

## 3 Year Limited Warranty Against Corrosion Failure

### WHAT IS COVERED

Mercury Marine warrants each new Mercury outboard, Mariner outboard, Mercury Racing, Jet Products, Thruster Electric Motor, Mercury Racing, Tracker by Mercury Marine Outboard, Mercruiser Inboard or sterndrive engine (Product) rendered inoperative as a direct result of corrosion for the period of time described below.

### DURATION OF COVERAGE

This limited corrosion warranty provides coverage for three (3) years from the date the product is first sold, or the date on which the product is first put into service, whichever occurs first. The repair or replacement of parts, or the performance of service under this warranty does not extend the life of this warranty beyond its original expiration date. Unexpired warranty coverage can be transferred to subsequent (noncommercial use) purchaser upon proper re-registration of the product.

### CONDITIONS THAT MUST BE MET IN ORDER TO OBTAIN WARRANTY COVERAGE

Warranty coverage is available only to retail customers that purchase from a Dealer authorized by Mercury Marine to distribute the product in the country in which the sale occurred, and then only after the Mercury Marine specified pre-delivery inspection process is completed and documented. Warranty coverage becomes available upon proper registration of the product by the authorized dealer. Corrosion prevention devices specified in the Operation and Maintenance Manual must be in use on the boat, and routine maintenance outlined in the Operation and Maintenance Manual must be timely performed (including without limitation the replacement of sacrificial anodes, use of specified lubricants, and touch-up of nicks and scratches) in order to maintain warranty coverage. If this maintenance is performed by the retail customer Mercury Marine reserves the right to make future warranty coverage contingent on proof of proper maintenance.

### WHAT MERCURY WILL DO

Mercury's sole and exclusive obligation under this warranty is limited to, at our option, repairing a corroded part, replacing such part or parts with new or Mercury Marine certified re-manufactured parts, or refunding the purchase price of the Mercury product. Mercury reserves the right to improve or modify products from time to time without assuming an obligation to modify products previously manufactured.

## **WARRANTY INFORMATION**

### **3 Year Limited Warranty Against Corrosion Failure**

#### **HOW TO OBTAIN WARRANTY COVERAGE**

The customer must provide Mercury with a reasonable opportunity to repair, and reasonable access to the product for warranty service. Warranty claims shall be made by delivering the product for inspection to a Mercury dealer authorized to service the product. If purchaser cannot deliver the product to such a dealer, written notice must be given to Mercury. We will then arrange for the inspection and any covered repair. Purchaser in that case shall pay for all related transportation charges and/or travel time. If the service provided is not covered by this warranty, purchaser shall pay for all related labor and material, and any other expenses associated with that service. Purchaser shall not, unless requested by Mercury, ship the product or parts of the product directly to Mercury. The warranty registration card is the only valid registration identification and must be presented to the dealer at the time warranty service is requested in order to obtain coverage.

## **WARRANTY INFORMATION**

### **3 Year Limited Warranty Against Corrosion Failure**

#### **WHAT IS NOT COVERED**

This limited warranty does not cover electrical system corrosion; corrosion resulting from damage, corrosion which causes purely cosmetic damage, abuse or improper service; corrosion to accessories, instruments, steering systems; corrosion to factory installed jet drive unit; damage due to marine growth; product sold with less than a one year limited Product warranty; replacement parts (parts purchased by customer); products used in a commercial application. Commercial use is defined as any work or employment related use of the product, or any use of the product which generates income, for any part of the warranty period, even if the product is only occasionally used for such purposes.

Corrosion damage caused by stray electrical currents (on-shore power connections, nearby boats, submerged metal) is not covered by this corrosion warranty and should be protected against by the use of a corrosion protection system, such as the Mercury Precision Parts or Quicksilver MerCathode system and/or Galvanic Isolator. Corrosion damage caused by improper application of copper base anti-fouling paints is also not covered by this limited warranty. If anti-foul-ing protection is required, Tri-Butyl-Tin-Adipate (TBTA) base anti-fouling paints are recommended on Outboard and MerCruiser boating applications. In areas where TBTA base paints are prohibited by law, copper base paints can be used on the hull and transom. Do not apply paint to the outboard or MerCruiser product. In addition, care must be taken to avoid an electrical interconnection between the warranted product and the paint. Refer to the Operation and Maintenance Manual for additional details.

For additional information regarding events and circumstances covered by this warranty, and those that are not, see the Warranty Coverage section of the Operation and Maintenance Manual, incorporated by reference into this warranty.

#### **DISCLAIMERS AND LIMITATIONS:**

**THE IMPLIED WARRANTIES OF MERCHANTABILITY AND FITNESS FOR A PARTICULAR PURPOSE ARE EXPRESSLY DISCLAIMED. TO THE EXTENT THAT THEY CANNOT BE DISCLAIMED, THE IMPLIED WARRANTIES ARE LIMITED IN DURATION TO THE LIFE OF THE EXPRESS WARRANTY. INCIDENTAL AND CONSEQUENTIAL DAMAGES ARE EXCLUDED FROM COVERAGE UNDER THIS WARRANTY. SOME STATES/COUNTRIES DO NOT ALLOW FOR THE DISCLAIMERS, LIMITATIONS AND EXCLUSIONS IDENTIFIED ABOVE, AS A RESULT, THEY MAY NOT APPLY TO YOU. THIS WARRANTY GIVES YOU SPECIFIC LEGAL RIGHTS, AND YOU MAY ALSO HAVE OTHER LEGAL RIGHTS WHICH VARY FROM STATE TO STATE AND COUNTRY TO COUNTRY.**

# WARRANTY INFORMATION

op5

## Warranty Coverage and Exclusions

The purpose of this section is to help eliminate some of the more common misunderstandings regarding warranty coverage. The following information explains some of the types of services that are not covered by warranty. The provisions set forth following have been incorporated by reference into the Three Year Limited Warranty Against Corrosion Failure, the International Limited Outboard Warranty, and the United States and Canada Limited Outboard Warranty.

Keep in mind that warranty covers repairs that are needed within the warranty period because of defects in material and workmanship. Installation errors, accidents, normal wear, and a variety of other causes that affect the product are not covered.

Warranty is limited to defects in material or workmanship, but only when the consumer sale is made in the country to which distribution is authorized by us.

Should you have any questions concerning warranty coverage, contact your authorized dealer. They will be pleased to answer any questions that you may have.

### GENERAL EXCLUSIONS FROM WARRANTY

1. Minor adjustments and tune-ups, including checking, cleaning or adjusting spark plugs, ignition components, carburetor settings, filters, belts, controls, and checking lubrication made in connection with normal services.
2. Factory Installed Jet Drive units – Specific parts excluded from the warranty are: The jet drive impeller and jet drive liner damaged by impact or wear, and water damaged drive shaft bearings as a result of improper maintenance.
3. Damage caused by neglect, lack of maintenance, accident, abnormal operation or improper installation or service.
4. Haul-out, launch, towing charges, removal and/or replacement of boat partitions or material because of boat design for necessary access to the product, all related transportation charges and/or travel time, etc. Reasonable access must be provided to the product for warranty service. Customer must deliver product to an authorized dealer.
5. Additional service work requested by customer other than that necessary to satisfy the warranty obligation.
6. Labor performed by other than an authorized dealer may be covered only under following circumstances: When performed on emergency basis (providing there are no authorized dealers in the area who can perform the work required or have no facilities to haul out, etc., and prior factory approval has been given to have the work performed at this facility).
7. All incidental and/or consequential damages (storage charges, telephone or rental charges of any type, inconvenience or loss of time or income) are the owner's responsibility.

# WARRANTY INFORMATION

op6

## Warranty Coverage and Exclusions

8. Use of other than Mercury Precision or Quicksilver parts when making warranty repairs.
9. Oils, lubricants or fluids changed as a matter of normal maintenance is customer's responsibility unless loss or contamination of same is caused by product failure that would be eligible for warranty consideration.
10. Participating in or preparing for racing or other competitive activity or operating with a racing type lower unit.
11. Engine noise does not necessarily indicate a serious engine problem. If diagnosis indicates a serious internal engine condition which could result in a failure, condition responsible for noise should be corrected under the warranty.
12. Lower unit and/or propeller damage caused by striking a submerged object is considered a marine hazard.
13. Water entering engine through the fuel intake, air intake or exhaust system. or submersion.
14. Failure of any parts caused by lack of cooling water, which results from starting motor out of water, foreign material blocking inlet holes, motor being mounted too high or trimmed too far out.
15. Use of fuels and lubricants which are not suitable for use with or on the product. Refer to the Maintenance Section.
16. Our limited warranty does not apply to any damage to our products caused by the installation or use of parts and accessories which are not manufactured or sold by us. Failures which are not related to the use of those parts or accessories are covered under warranty if they otherwise meet the terms of the limited warranty for that product.

## GENERAL INFORMATION

oba2

### Boater's Responsibilities

The operator (driver) is responsible for the correct and safe operation of the boat and safety of its occupants and general public. It is strongly recommended that each operator (driver) read and understand this entire manual before operating the outboard.

Be sure at least one additional person on board is instructed in the basics of starting and operating the outboard and boat handling in case the driver is unable to operate the boat.

This manual as well as safety labels posted on the outboard use the following safety alerts to draw your attention to special safety instructions that should be followed.

#### **DANGER**

**DANGER** – Immediate hazards which **WILL** result in severe personal injury or death.

#### **WARNING**

**WARNING** – Hazards or unsafe practices which **COULD** result in severe personal injury or death.

#### **CAUTION**

**CAUTION** – Hazards or unsafe practices which could result in minor injury or product or property damage.

## GENERAL INFORMATION

obb2

### Before Operating Your Outboard

Read this manual carefully. Learn the difference in handling characteristics between a jet drive boat and a propeller driven boat including:

- *Steering at low speeds* - unlike propeller driven boats, the jet drive boat tends to lose steering control as less water is drawn in and expelled. Increase speed slightly to regain steering.
- *Maneuverability* - the jet drive is highly maneuverable at higher speeds, more so, than propeller driven boats. Use caution when turning to prevent spin-outs.
- *In neutral* - the impeller continues to rotate. Although the approximate balancing of forward and reverse thrust will minimize boat movement, the boat may tend to creep slowly forward or backward. This is normal for a direct-drive jet-driven boat. The operator should be aware of this and use caution whenever the engine is running.

If you have any questions, contact your dealer.

Safety and operating information that is practiced along with using good common sense can help prevent personal injury and product damage.

## GENERAL INFORMATION

gob35

U.S. COAST GUARD CAPACITY	
MAXIMUM HORSEPOWER	XXX
MAXIMUM PERSON CAPACITY (POUNDS)	XXX
MAXIMUM WEIGHT CAPACITY	XXX

1

obc1

### Boat Horsepower Capacity

- 1 Do not overpower or overload your boat. Most boats will carry a required capacity plate indicating the maximum acceptable power and load as determined by the manufacturer following certain federal guidelines. If in doubt, contact your dealer or the boat manufacturer.

### WARNING

Using an outboard that exceeds the maximum horsepower limit of a boat can: 1. cause loss of boat control 2. place too much weight at the transom altering the designed flotation characteristics of the boat or 3. cause the boat to break apart particularly around the transom area. Overpowering a boat can result in serious injury, death, or boat damage.

## GENERAL INFORMATION

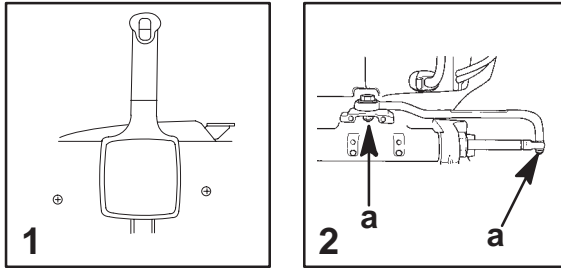

### Outboard Remote Control

- 1 The remote control connected to your outboard must be equipped with a “start-in-neutral” only protection device. This prevents the engine from starting when the shift is actuated in any position other than neutral.

#### **⚠ WARNING**

Avoid serious injury or death from a sudden unexpected acceleration when starting your engine. The design of this outboard requires that the remote control used with it must have a built in “start-in-neutral” only protection device.

### Remote Steering Notice

- 2 The steering link rod that connects the steering cable to the engine must be fastened utilizing self-locking nuts (a). These self- locking nuts must never be replaced with common nuts (non locking) as they will work loose and vibrate off, freeing the link rod to disengage.

#### **⚠ WARNING**

Disengagement of a steering link rod can result in the boat taking a full, sudden, sharp turn. This potentially violent action can cause occupants to be thrown overboard exposing them to serious injury or death.

## GENERAL INFORMATION

gob8

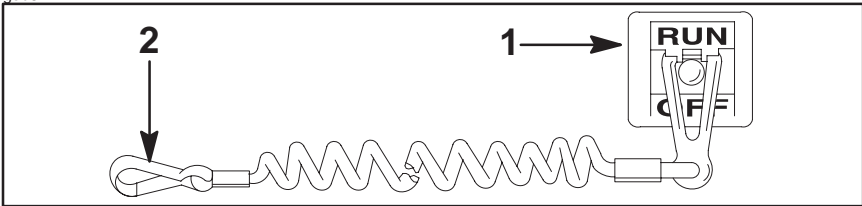

obg8

### Lanyard Stop Switch

- 1 The purpose of a lanyard stop switch is to turn off the engine when the operator moves far enough away from the operator's position (as in accidental ejection from the operator's position) to activate the switch. Tiller handle outboards and some remote control units are equipped with a lanyard stop switch. A lanyard stop switch can be installed as an accessory – generally on the dashboard or side adjacent to the operator's position.
- 2 The lanyard is a cord usually between 4 and 5 feet (1220 and 1524 mm) in length when stretched out with an element on one end made to be inserted into the switch and a snap on the other end for attaching to the operator. The lanyard is coiled to make its at-rest condition as short as possible so as to minimize the likelihood of lanyard entanglement with nearby objects. It is made as long as it is in its stretched condition to minimize the likelihood of accidental activation should the operator choose to move around in an area close to the normal operator's position. If it is desired to have a shorter lanyard, wrap the lanyard around the operator's wrist or leg, or tie a knot in the lanyard.

(continued on next page)

## GENERAL INFORMATION

### Lanyard Stop Switch (Continued)

Read the following Safety Information before proceeding.

**Important Safety Information:** The purpose of a lanyard stop switch is to stop the engine when the operator moves far enough away from the operator's position to activate the switch. This would occur if the operator accidentally falls overboard or moves within the boat a sufficient distance from the operator's position. Accidental ejections and falls overboard are more likely to occur in certain types of boats such as low sided inflatables or bass boats, high-performance boats and light, sensitive-handling fishing boats operated by hand-tiller. Accidental ejections and falls overboard are also likely to occur as a result of poor operating practices such as sitting on the back of the seat or gunwale at planing speeds, standing at planing speeds, sitting on elevated fishing boat decks, operating at planing speeds in shallow or obstacle-infested waters, releasing your grip on a steering wheel or tiller handle that is pulling in one direction, drinking alcohol or consuming drugs, or daring, high-speed boat maneuvers.

While activation of the lanyard stop switch will stop the engine immediately, a boat will continue to coast for some distance depending upon the velocity and degree of any turn at shut-down. However, the boat will not complete a full circle. While the boat is coasting, it can cause injury to anyone in the boat's path as seriously as the boat would when under power.

We strongly recommend that other occupants be instructed on proper starting and operating procedures should they be required to operate the engine in an emergency (e.g. if the operator is accidentally ejected).

#### **WARNING**

**Should the operator fall out of the boat, the possibility of serious injury or death from being run over by the boat can be greatly reduced by stopping the engine immediately. Always properly connect both ends of the stop switch lanyard – to the stop switch and the operator.**

(continued on next page)

## GENERAL INFORMATION

### Lanyard Stop Switch (Continued)

Accidental or unintended activation of the switch during normal operation is also a possibility. This could cause any, or all, of the following potentially hazardous situations:

1. Occupants could be thrown forward due to unexpected loss of forward motion – a particular concern for passengers in the front of the boat who could be ejected over the bow and possibly struck by the hull.
2. Loss of power and directional control in heavy seas, strong current or high winds.
3. Loss of control when docking.

#### WARNING

**Avoid serious injury or death from deceleration forces resulting from accidental or unintended stop switch activation. The boat operator should never leave the operator's station without first disconnecting the stop switch lanyard from the operator.**

### Stopping The Boat In An Emergency

Your jet powered boat has emergency stopping capability unique to this form of propulsion.

In an emergency, putting the remote control handle into reverse and applying reverse throttle can rapidly slow down your boat and reduce the stopping distance. Keep in mind, however, that such a maneuver may cause occupants in the boat to be thrown forward or even out of the boat.

#### WARNING

**Using the emergency stopping capability of your jet drive will slow down your boat in an emergency. However keep in mind, sudden stopping may cause the occupants in the boat to be thrown forward or even out of the boat. This action may result in serious injury or death.**

ob

## GENERAL INFORMATION

gob3

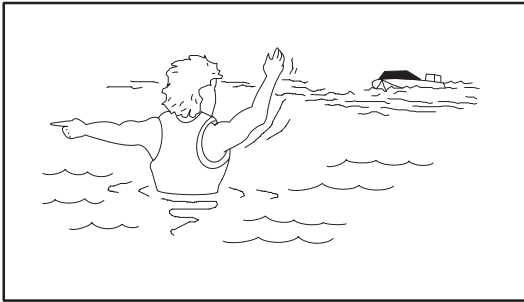

obh3

### Protecting People In The Water

#### WHILE YOU ARE CRUISING

It is very difficult for a person standing or floating in the water to take quick action to avoid a boat heading in their direction even at slow speed.

Always slow down and exercise extreme caution any time you are boating in an area where there might be people in the water.

Avoid shallow water or where any loose material such as sand, shells, seaweed, grass, tree branches, etc. can be sucked in and expelled from the the pump as a high speed projectile.

obp1

#### WHILE BOAT IS STATIONARY

Stop the engine immediately whenever anyone in the water is near your boat. The jet drive is always drawing water through the water intake grate when the engine is running. Stay away from the water intake located under the jet drive and never insert an object into the water intake or water outlet nozzle when the engine is running.

#### **⚠ WARNING**

**Avoid injury resulting from contacting the rotating impeller or having your hair, clothing or loose objects drawn into the water intake and wrapping around the impeller shaft. Stay away from the water intake and never insert an object into the water intake or water outlet nozzle when the engine is running.**

bob

## GENERAL INFORMATION

gob4

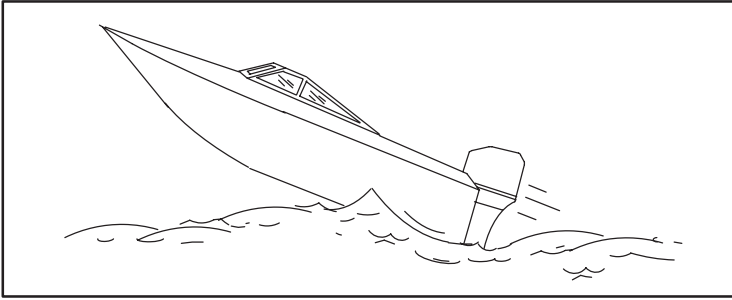

obu1

### Wave And Wake Jumping

Operating recreational boats over waves and wakes is a natural part of boating. However, when this activity is done with sufficient speed to force the boat hull partially or completely out of the water, certain hazards arise, particularly when the boat re-enters the water.

The primary concern is the boat changing direction while in the midst of the jump. In such case the landing may cause the boat to veer violently in a new direction. Such a sharp change in direction can cause occupants to be thrown out of their seats, or out of the boat.

There is another less common hazardous result from allowing your boat to launch off a wave or wake. If the bow of your boat pitches down far enough while airborne, upon water contact it may penetrate under the water surface and “submarine” for an instant. This will bring the boat to a nearly instantaneous stop and can send the occupants flying forward. The boat may also steer sharply to one side.

### WARNING

**Avoid serious injury or death from being thrown within or out of a boat when it lands after jumping a wave or wake. Avoid wave or wake jumping whenever possible. Instruct all occupants that if a wake or wave jump occurs, get low and hang on to any boat hand hold.**

## GENERAL INFORMATION

gob4

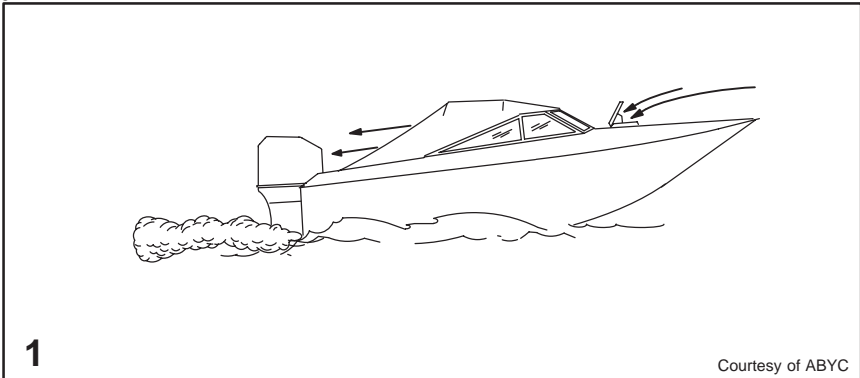

obi2

### Exhaust Emissions

#### BE ALERT TO CARBON MONOXIDE POISONING

Carbon monoxide is present in the exhaust fumes of all internal combustion engines including the outboards, sterndrives and inboard engines that propel boats, as well as the generators that power various boat accessories. Carbon monoxide is a deadly gas that is odorless, colorless and tasteless.

Early symptoms of carbon monoxide poisoning which should not be confused with seasickness or intoxication, include headache, dizziness, drowsiness, and nausea.

#### **⚠ WARNING**

**Avoid the combination of a running engine and poor ventilation. Prolonged exposure to carbon monoxide in sufficient concentration can lead to unconsciousness, brain damage, or death.**

#### GOOD VENTILATION

Ventilate passenger area, open side curtains, or forward hatches to remove fumes.

#### **1 Example of desired air flow through the boat.**

## GENERAL INFORMATION

gob39

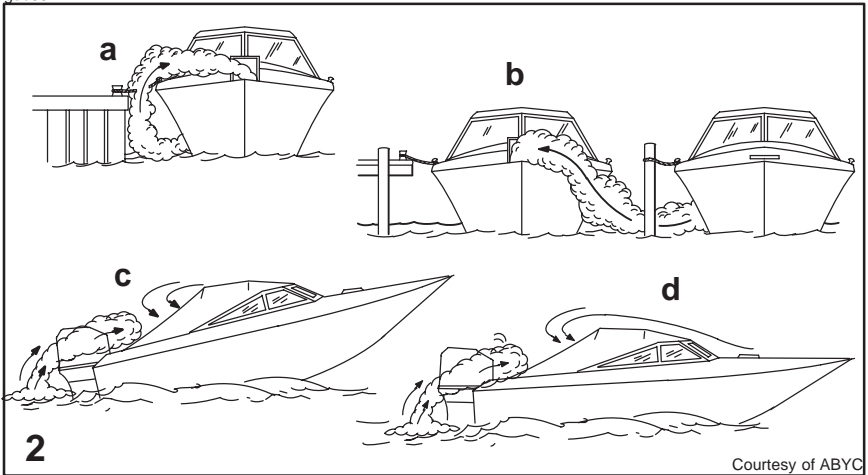

obi3

### Exhaust Emissions (Continued)

#### POOR VENTILATION

Under certain running and/or wind conditions, permanently enclosed or canvas enclosed cabins or cockpits with insufficient ventilation may draw in carbon monoxide. Install one or more carbon monoxide detectors in your boat.

Although the occurrence is rare, on a very calm day, swimmers and passengers in an unclosed area of a stationary boat that contains or is near a running engine may be exposed to a hazardous level of carbon monoxide.

#### 2 Examples of Poor Ventilation:

While boat is stationary

- a. Running the engine when the boat is moored in a confined space.
- b. Mooring close to another boat that has its engine running.

While boat is moving

- c. Running the boat with the trim angle of the bow too high.
- d. Running the boat with no forward hatches open (station wagon effect).

## GENERAL INFORMATION

obj2

### Selecting Accessories For Your Outboard

Genuine Mercury Precision or Quicksilver Accessories have been specifically designed and tested for your outboard. These accessories are available from Mercury Marine dealers.

Some accessories not manufactured or sold by Mercury Marine are not designed to be safely used with your outboard or outboard operating system. Acquire and read the installation, operation, and maintenance manuals for all your selected accessories.

#### WARNING

**Check with your dealer before installation of accessories. The misuse of acceptable accessories or the use of unacceptable accessories can result in serious injury, death, or product failure.**

obk2

### Safe Boating Suggestions

In order to safely enjoy the waterways, familiarize yourself with local and other government boating regulations and restrictions, and consider the following suggestions.

**Use flotation devices.** Have an approved personal flotation device of suitable size for each person aboard (it is the law) and have it readily accessible.

**Do not overload your boat.** Most boats are rated and certified for maximum load (weight) capacities (refer to your boat capacity plate). If in doubt, contact your dealer or the boats manufacturer.

**Perform safety checks and required maintenance.** Follow a regular schedule and ensure that all repairs are properly made.

(continued on next page)

## GENERAL INFORMATION

### Safe Boating Suggestions (Continued)

**Know and obey all nautical rules and laws of the waterways.** Boat operators should complete a boating safety course. Courses are offered in the U.S.A. by (1) The U.S. Coast Guard Auxiliary, (2) The Power Squadron, (3) The Red Cross and (4) your state boating law enforcement agency. Inquiries may be made to the Boating Hot-line, 1-800-368-5647 or the Boat U.S. Foundation information number 1-800-336-BOAT.

**Make sure everyone in the boat is properly seated.** Don't allow anyone to sit or ride on any part of the boat that was not intended for such use. This includes backs of seats, gunwales, transom, bow, decks, raised fishing seats, any rotating fishing seat; anywhere that sudden unexpected acceleration, sudden stopping, unexpected loss of boat control or sudden boat movement could cause a person to be thrown overboard or into the boat.

**Never be under the influence of alcohol or drugs while boating (it is the law).** They impair your judgment and greatly reduce your ability to react quickly.

**Prepare other boat operators.** Instruct at least one person on board in the basics of starting and operating the outboard and boat handling in case the driver becomes disabled or falls overboard.

**Passenger boarding.** Stop the engine whenever passengers are boarding, unloading or are near the back (stern) of the boat. Just shifting the outboard into neutral is not sufficient.

**Be alert.** The operator of the boat is responsible by law to "maintain a proper lookout by sight (and hearing)." The operator must have an unobstructed view particularly to the front. No passengers, load, or fishing seats should block the operators view when operating the boat above idle speed.

**Avoid shallow water conditions.** Never operate your jet drive in very shallow water or where there is a noticeable amount of floating debris or weeds. Any loose material such as sand, stones, seaweed, grass, tree branches etc. can be sucked up by the pump and may not only block the water flow and cause loss of steering control but can be expelled from the rear of the pump as a high-speed projectile.

(continued on next page)

## GENERAL INFORMATION

### Safe Boating Suggestions (Continued)

**Watch for boat creeping in neutral.** When the jet drive is in neutral, the drive impeller continues to rotate. Although the approximate balancing of forward and reverse thrust will minimize boat movement, the boat may tend to creep slowly forward or backward. This is normal for a direct-drive jet-driven boat. The operator should be aware of this and use caution whenever the engine is running.

**Never drive your boat directly behind a water skier in case the skier falls.** As an example, your boat traveling at 25 miles per hour (40 km/hr) in 5 seconds will overtake a fallen skier who was 200 feet (61m) in front of you.

**Watch fallen skiers.** When using your boat for water skiing or similar activities, always keep a fallen or down skier on the operator's side of the boat while returning to attend the skier. The operator should always have the down skier in sight and never back up to the skier or anyone in the water.

**Report accidents.** Boat operators are required by law to file a Boating Accident Report with their state boating law enforcement agency when their boat is involved in certain boating accidents. A boating accident must be reported if (1) there is loss of life or probable loss of life, (2) there is personal injury requiring medical treatment beyond first aid, (3) there is damage to boats or other property where the damage value exceeds \$500.00 or (4) there is complete loss of the boat. Seek further assistance from local law enforcement.

ob

# GENERAL INFORMATION

obl9

## Recording Serial Number

It is important to record this number for future reference. The serial number is located on the outboard as shown.

- a - Serial Number
- b - Model Year
- c - Model Designation
- d - Year Manufactured
- e - Certified Europe Insignia (as Applicable)

gob24

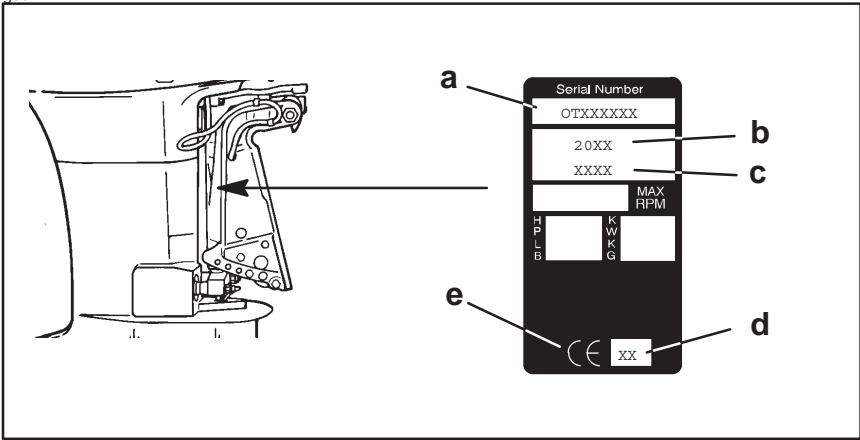

## GENERAL INFORMATION

obm59

### Specifications

<b>Models</b>	<b>65</b>	<b>80</b>
Jet Power	65	80
Engine Horsepower	90	115
Full Throttle RPM Range	5000-5500	4750-5250
Idle Speed in Forward Gear	650-700 RPM	
Number of Cylinders	3	4
Piston Displacement	84.57 cu. in. (1385.8cc)	112.76 cu. in. (1847.8cc)
Cylinder Bore	3.500 in. (88.9mm)	
Stroke	2.930 in. (74mm)	
Recommended Spark Plug	NGK BUZHW-2	NGK BPZ8H-N-10
Spark Plug Gap	Surface Gap	.040 in. (1.0mm)
Recommended Gasoline	Refer to Fuel Section	
Recommended Oil	Refer to Fuel Section	
Battery Rating	630 Marine Cranking Amps (MCA) or 490 Cold Cranking Amps (CCA)	

# GENERAL INFORMATION

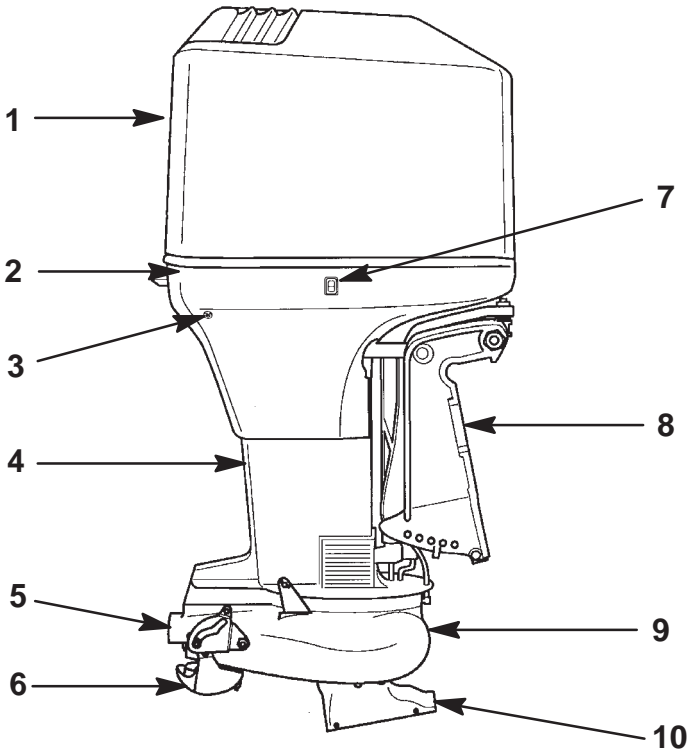

## Component Identification

1. Top Cowl
2. Bottom Cowl
3. Water Pump Indicator Hole
4. Drive Shaft Housing
5. Water Outlet Nozzle
6. Reverse Gate
7. Auxiliary Tilt Switch
8. Transom Brackets
9. Jet Drive Housing
10. Water Intake Housing

## INSTALLATION

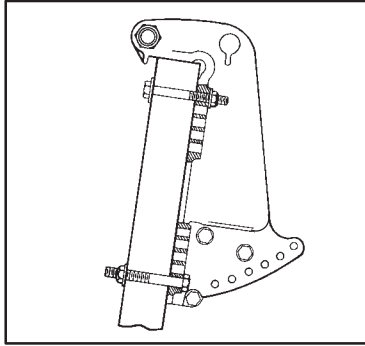

### Installing Outboard

#### **⚠ WARNING**

**Before operation, the outboard must be correctly installed with four mounting bolts shown. Failure to correctly fasten outboard could result in outboard ejecting off boat transom causing serious injury, death, or property damage.**

We strongly recommend that your dealer install your outboard and related accessories to ensure proper installation and good performance. If you install the outboard yourself, follow instructions in the Outboard Installation Manual which is provided with the outboard.

The outboard must be secured to the transom with the four 1/2 inch diameter mounting bolts and locknuts provided with the outboard. Install two bolts thru the upper set of holes and two bolts thru the lower set of holes.

## TRANSPORTING

### Trailer Boat/Outboard

Trailer your boat with the outboard tilted down (vertical operating position).

If additional ground clearance is required, the outboard should be tilted up using an accessory outboard support device. Refer to your local dealer for recommendations. Additional clearance may be required for railroad crossings, driveways and trailer bouncing.

**IMPORTANT: Do not rely on the power trim/tilt system or tilt support lever to maintain proper ground clearance for trailering. The outboard tilt support lever is not intended to support the outboard for trailering.**

# FUEL & OIL

oeb6

## Gasoline Recommendations

### UNITED STATES AND CANADA

Use a major brand of automotive unleaded gasoline with a minimum posted octane rating of 87. Mid-grade automotive gasolines that contain fuel injector cleaner are preferred for added internal engine cleanliness. Leaded gasoline is not recommended.

### INTERNATIONAL

Use a major brand of automotive unleaded gasoline with a minimum posted octane rating of 90RON. Automotive gasolines that contain fuel injector cleaner are preferred for added internal engine cleanliness. Leaded gasoline is acceptable in areas where unleaded gasoline is not available.

### ALCOHOL IN GASOLINE

We do not recommend the use of gasoline which contains alcohol because of the possible adverse effect the alcohol may have on the fuel system. In general, if only gasoline containing alcohol is available, it must not contain more than 10% ethanol or 5% methanol, and the addition of a Water Separating Fuel Filter is recommended.

If gasoline containing alcohol is used or if you suspect the presence of alcohol in your gasoline, increase your inspection of the fuel system, visually checking for fuel leaks or abnormalities.

Gasoline containing alcohol may cause the following problems to your outboard and fuel system:

- Corrosion of metal parts.
- Deterioration of elastomers and plastic parts.
- Wear and damage of internal engine parts.
- Starting and operating difficulties.
- Vapor lock or fuel starvation.

Some of these adverse effects are due to the tendency of gasoline containing alcohol to absorb moisture from the air, resulting in a phase of water and alcohol which separates from the gasoline in the fuel tank.

The adverse effects of alcohol are more severe with methanol and are worse with increasing content of alcohol.

## FUEL & OIL

oec13

### Oil Recommendation

Mercury or Quicksilver Premium TC-W3 2-cycle oil is recommended for your engine. For added protection and lubrication, Mercury or Quicksilver Premium Plus TC-W3 2-cycle oil is recommended. If Mercury or Quicksilver outboard oil is not available, substitute another brand of 2-cycle outboard oil that is NMMA Certified TC-W3. Severe engine damage may result from use of an inferior oil.

oeg4

### New Engine Gasoline/Oil Break-in Mixture

Use a 50:1 (2%) gasoline/oil mixture in the first tank of fuel. Follow the table below for mixing ratios. Use of this fuel mixture combined with oil from the oil injection system will supply adequate lubrication during engine break-in.

After the break-in fuel mixture is used up, it is no longer necessary to add oil with the gasoline.

*NOTE: At the end of the break-in period, visually check to see if the oil level in the oil injection tank has dropped. Oil usage indicates the oil injection system is functioning correctly.*

oeh2

### GASOLINE/OIL MIXING RATIO CHART

<b>Gas/ Oil Ratio</b>	<b>1 Gallon Gas (3.8 Liters)</b>	<b>3 Gallons Gas (11.5 Liters)</b>	<b>6 Gallons Gas (23 Liters)</b>
<b>50:1 (2%)</b>	3 fl. oz. (89 ml) Oil	8 fl. oz. (237 ml) Oil	16 fl. oz. (473 ml) Oil

oen1

### Mixing Gasoline/Oil – For Break-in

**Portable Tank** – Pour one gallon (4 liters) of gasoline into tank. Add the correct amount of oil and mix thoroughly. Add the remainder of gasoline.

**Built-in Tank** – Using a funnel, pour the correct amount of oil slowly with the gasoline as tank is filled.

## FUEL & OIL

goe7

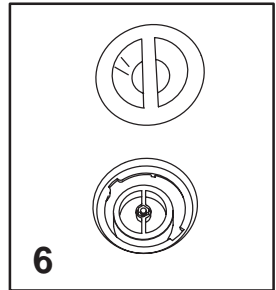
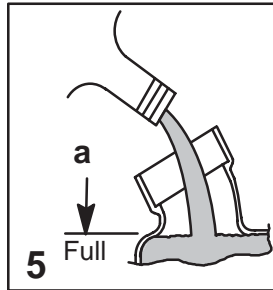
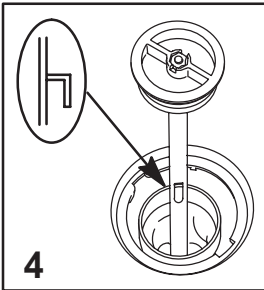
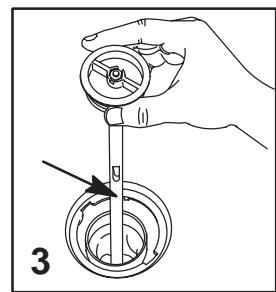
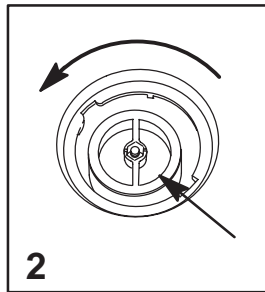
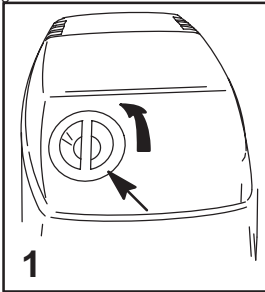

oem4

### Filling Oil Injection System

- 1 Position the outboard in a level operating position. Remove the cowl cap.
- 2 Turn the oil filler cap to the left and remove.
- 3 Use the dipstick to check oil level.
- 4 Hook the dipstick on the tank during filling.
- 5 Slowly fill the oil tank with the specified oil. **Do Not overfill** – add only enough oil to bring the oil level up to the bottom of the fill neck (a).

*NOTE: The oil tank capacity for three cylinder models is 3.2 qt. (3.0 liters) and four cylinder models is 5.13 qt. (4.9 liters).*

- 6 Install oil filler cap and re-tighten. Reinstall the cowl cap.

## FUEL & OIL

### Filling Fuel Tank

#### WARNING

**Avoid serious injury or death from a gasoline fire or explosion. Always stop the engine and DO NOT smoke or allow open flames or sparks in the area while filling fuel tanks.**

Fill fuel tanks outdoors away from heat, sparks, and open flames.

Remove portable fuel tanks from boat to refill them.

Always stop engine before refilling tanks.

Do not completely fill the fuel tanks. Leave approximately 10% of the tank volume unfilled. Fuel will expand in volume as its temperature rises and can leak under pressure if the tank is completely filled.

#### **PORTABLE FUEL TANK PLACEMENT IN THE BOAT**

Place the fuel tank in the boat so that the tank vent will stay higher than the fuel level in the tank under normal boat operating conditions.

## FEATURES & CONTROLS

gog142

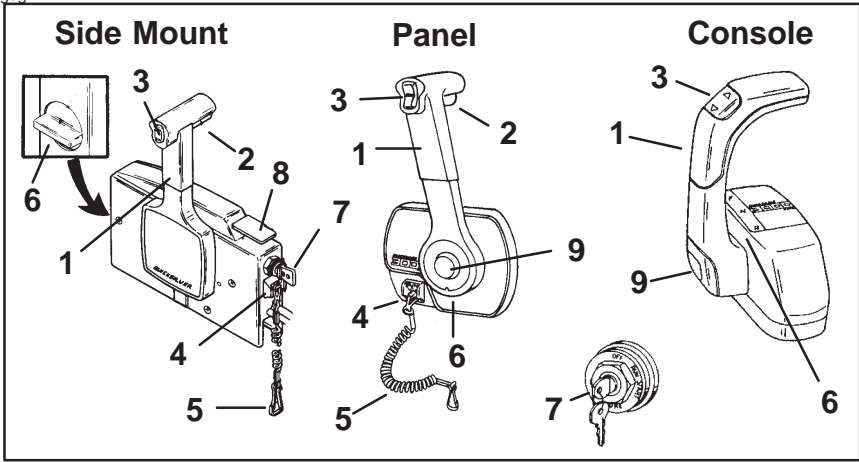

oge11

### Remote Control Features

Your boat may be equipped with one of the Mercury Precision or Quicksilver remote controls shown. If not, consult your dealer for a description of the functions and operations of the remote control.

- 1** Control Handle – Forward, Neutral, Reverse.
- 2** Neutral Release Lever.
- 3** Trim/Tilt Switch (if Equipped) – Refer to Power Trim Operation.
- 4** Lanyard Stop Switch – Read the Lanyard Stop Switch safety explanation and Warning in the General Information Section.
- 5** Lanyard – Read the lanyard stop switch safety explanation and warning in the General Information Section.
- 6** Throttle Friction Adjustment – Console Controls require cover removal for adjustment.
- 7** Ignition Key Switch – Off, On, Start, Choke.
- 8** Fast Idle Lever – Raising lever will increase engine idle speed in neutral. Refer to Starting the Engine in the Operation Section.
- 9** Throttle Only Button – Pushing in the button will enable you to advance the control handle for increasing engine idle speed without shifting outboard into gear. Refer to Starting the Engine in the Operation Section.

## FEATURES & CONTROLS

gog49

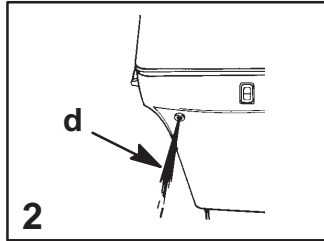
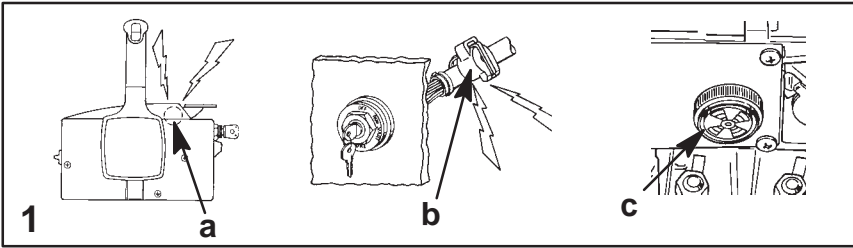

ogb35

### Warning System

- 1 The outboard warning system incorporates a warning horn inside the boat. The warning horn on remote control operated models may be located (a) inside the remote control or (b) connected to the key switch under the dash. On tiller handle models the warning horn is located below the tiller handle (c).

The warning horn will emit a continuous beep. This will alert the operator to one of two problems: EITHER an engine overheat condition OR low oil level in the oil injection tank. See explanations "2" and "3" following.

- 2 **Engine overheat.** If the engine overheats, the warning horn will sound. Immediately reduce throttle speed to idle. Shift outboard into neutral and check for a steady stream of water (d) coming out of the water pump indicator hole.

If no water (d) is coming out of the water pump indicator hole or flow is intermittent, stop engine and check water intake for obstruction. If no obstruction is found, this may indicate a blockage in the cooling system or a water pump problem. Have the outboard checked by your dealer. Operating the engine while overheated will cause engine damage. See the following note.

(continued on next page)

## FEATURES & CONTROLS

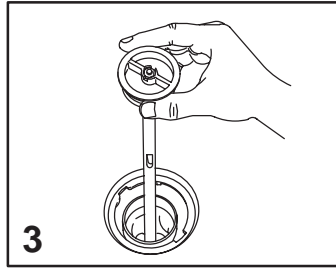
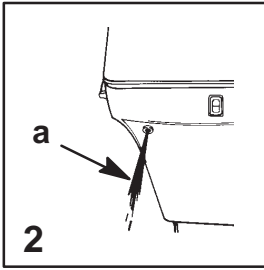

### Warning System

#### 2 Engine overheat (Continued)

If a steady stream of water (a) is coming out of the water pump indicator hole, and the warning horn continues to sound, there still may be insufficient cooling water or an engine problem. Stop engine and have it checked by your dealer. Operating the engine while overheated will cause engine damage. See the following note.

*NOTE: Should this occur and you are in a stranded situation, stopping the engine and allowing it to cool back down will usually allow some additional low speed (idle) running time before the engine starts to overheat again.*

The overheat problem must be corrected before you can resume normal operation.

**3 Low oil level in the oil injection system.** If the oil level drops below the low oil level, the warning horn will sound. You still have an oil reserve remaining for 30 minutes of full speed operation. Refer to Fuel Section for refilling instructions.

## FEATURES & CONTROLS

gog87

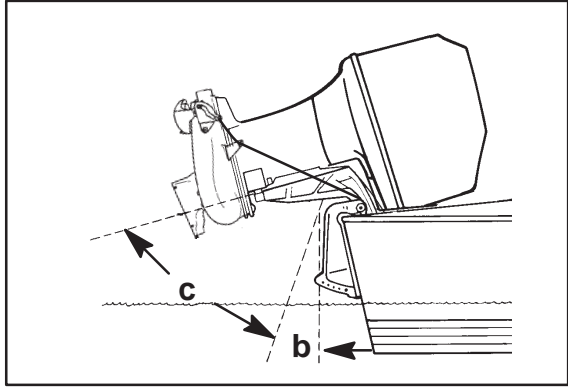
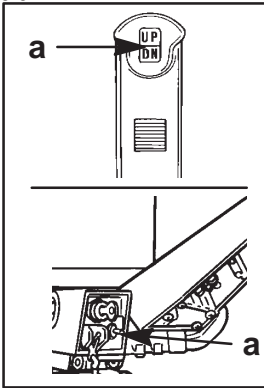

ogc16

### Power Trim And Tilt

Your outboard has a trim/tilt control called "Power Trim." This enables the operator to easily adjust the position of the outboard by pressing the trim switch (a). Moving the outboard in closer to the boat transom is called trimming "in" or "down." Moving the outboard further away from the boat transom is called trimming "out" or "up." The term "trim" generally refers to the adjustment of the outboard within the first 20° range of travel (b). The term "tilt" is generally used when referring to adjusting the outboard further up out of the water (c). With the engine turned off, the outboard can be tilted out of the water.

### POWER TRIM OPERATION

The power trim and tilt feature of your outboard is convenient for drifting and when operating at low throttle speed in very shallow water. When under power, however, do not trim out the outboard in an effort to gain speed as is done with a conventional propeller driven boat.

When planing, the outboard should be positioned vertical or tilted in toward the boat to provide a scooping angle on the water intake grate. Tilting the outboard out beyond a vertical position reduces the scoop angle and can cause impeller slippage and cavitation burns on the impeller blades.

## FEATURES & CONTROLS

gog62

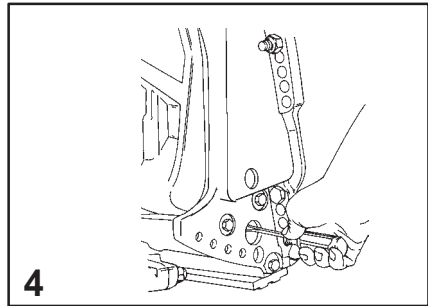
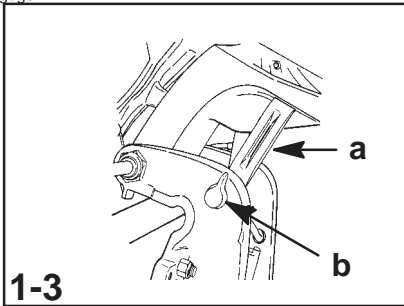

ogc26

### Power Trim And Tilt

#### TILTING OPERATION

To tilt outboard, shut off the engine and press the trim/tilt switch or auxiliary tilt switch to the up position. The outboard will tilt up until the switch is released or it reaches its maximum tilt position.

- 1** Engage the tilt support lever (a), by rotating knob (b) to bring support lever upward.
- 2** Lower outboard to rest on the tilt support lever.
- 3** Disengage the tilt support lever, by raising the outboard off the support lever and rotating the lever down. Lower the outboard.

#### MANUAL TILTING

If the outboard cannot be tilted using the power trim/tilt switch, the outboard can be manually tilted.

- 4** Turn out the manual tilt release valve 3 turns (counterclockwise). This allows manual tilting of the outboard. Tilt the outboard to the desired position and tighten the manual tilt release valve.

*NOTE: The manual tilt release valve must be tightened before operating the outboard to prevent the outboard from tilting up during reverse operation.*

## FEATURES & CONTROLS

gog88

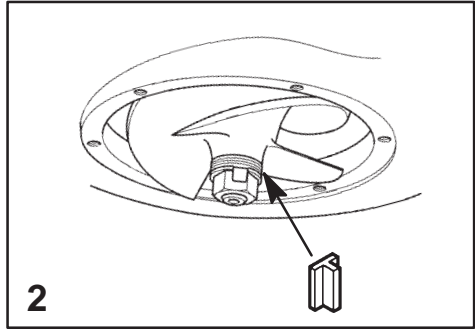
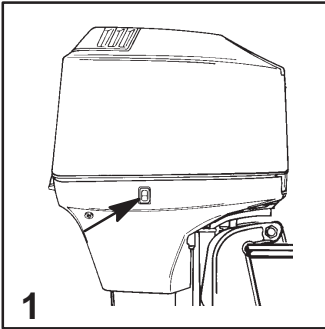

ogc15

### Power Trim And Tilt (Continued)

#### AUXILIARY TILT SWITCH

- 1** This switch can be used to tilt the outboard up or down using the power trim system.

#### Replaceable Jet Drive Shear Key

- 2** Your jet drive is equipped with a shear key to protect it in the event of a jammed impeller. The shear key can be reached by removing the water intake housing and impeller. Refer to Impeller Removal and Installation in the Maintenance Section.

## OPERATION

ofa4

### Pre-Starting Check List

- Operator knows safe navigation, boating, and operating procedures.
- An approved personal flotation device of suitable size for each person aboard and readily accessible (it is the law).
- A ring type life buoy or buoyant cushion designed to be thrown to a person in the water.
- Know your boats maximum load capacity. Look at the boat capacity plate.
- Fuel supply OK.
- Oil supply (oil injection) OK.
- Make sure the boat drain plug is installed.
- Arrange passengers and load in the boat so the weight is distributed evenly and everyone is seated in a proper seat.
- Tell someone where you are going and when you expect to return.
- It is illegal to operate a boat while under the influence of alcohol or drugs.
- Know the waters and area you will be boating; tides, currents, sand bars, rocks, and other hazards.
- Make inspection checks listed in the Inspection and Maintenance Schedule. Refer to Maintenance Section.
- Check steering for free operation.
- Check for debris around the rudder and reverse gate which may jam or hinder operation.
- Before launching, examine the jet drive water intake for obstructions which may prevent pumping of water.
- Make sure the drive shaft bearing on the jet drive is lubricated.

# OPERATION

gof92

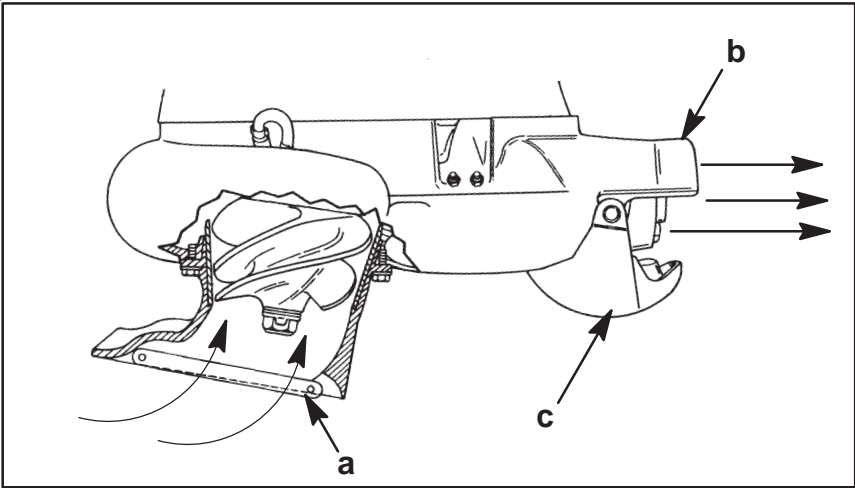

onm1

## How The Jet Drive Operates

A jet-driven boat has substantially different handling characteristics compared to a propeller-driven boat. It is suggested that you adjust yourself to these characteristics by experimentation in open water at both high and low speeds.

The drive shaft driven impeller draws water up through the water intake (a) and then redirects it at a high pressure through the water outlet nozzle (b) to create forward thrust. To obtain reverse, the reverse gate (c) is swung over the outlet nozzle to direct the water in the opposite direction for reverse operation.

When the jet drive is in neutral, the impeller continues to rotate. However, the reverse gate is positioned so that some of the forward thrust is diverted to create reverse thrust. This approximate balancing of forward and reverse thrust will minimize any boat movement. However, because the impeller is always rotating and creating thrust when the engine is running, the boat may tend to creep slowly forward or backward. This is normal for a direct-drive, jet-driven boat. The operator should be aware of this and use caution whenever the engine is running.

(continued on next page)

## OPERATION

### How The Jet Drive Operates (Continued)

The jet drive is always drawing water into the housing when the engine is running. DO NOT operate the jet drive with the grate removed from the water intake. Keep your hands, feet, hair, loose clothing, life jackets, etc. away from the water intake. Never insert an object into the water intake or water outlet nozzle when the engine is running.

#### WARNING

**Avoid injury resulting from contacting the rotating impeller or having your hair, clothing, or loose objects drawn into the water intake and wrapping around the impeller. Stay away from the water intake and never insert an object into the water intake or water outlet nozzle when the engine is running.**

ofz1

### Stopping The Boat In An Emergency

Your jet powered boat has emergency stopping capability unique to this form of propulsion.

In an emergency, shifting the jet drive into reverse and applying reverse throttle can rapidly slow down your boat and reduce the stopping distance. Keep in mind, however, that such a maneuver may cause occupants in the boat to be thrown forward or even out of the boat.

#### WARNING

**Using the emergency stopping capability of your jet drive will slow down your boat in an emergency. However, keep in mind, sudden stopping may cause the occupants in the boat to be thrown forward or even out of the boat. This action may result in serious injury or death.**

of

## OPERATION

only

### Steering Your Boat

The jet drive is dependent on water jet thrust for steering the boat. The jet drive has a steerable outlet nozzle that directs this water jet thrust to the right or left. If the water jet thrust should ever stop, (water blockage, the engine stops, or, etc.) will cause the boat to slow to a stop. However, while slowing there will be a reduced ability to steer the boat.

While steering your outboard, you will find quick response to the helm, but due to the relatively flat-bottom hulls and lack of a gear case in the water, your boat will tend to skid on the turns. You must start your turns early and use sufficient power to maintain steering control.

#### **WARNING**

**Avoid serious injury or death. Do not attempt to steer your boat into a tight turn; at too high a speed, your boat could “spin out” or even roll over, resulting in occupants being thrown within the boat or out of the boat.**

#### **WARNING**

**Avoid injury, death or property damage resulting from collision due to loss of directional control. Directional control is derived from the water jet thrust. Thus, caution should be exercised when maneuvering at higher speeds in areas where debris (weeds, logs, gravel, etc.) could be picked up into the jet drive. This can cut off or reduce the water jet thrust, thereby directly affecting boat directional control. Boat directional control can also be substantially reduced or lost altogether by a sudden loss of power such as running out of gas, quickly backing off throttle, turning off ignition switch, or activating lanyard stop switch. Remember your ability to take evasive action is dependent on sufficient water jet thrust to control your boat.**

of

## OPERATION

onk1

### Operating In Shallow Water

The life of the impeller and water intake can be greatly increased by avoiding the intake of sand and gravel. The intake suction, acting on the bottom, will act like a dredge when the water intake comes within 2 to 3 inches of the bottom. It is better to stop the engine and drift up to shore when landing, and to shove off with an oar when leaving. You can idle through areas of water less than 1-foot deep, but there should be more than 1-foot of water under the boat when increasing speed to reach full plane.

Once the boat is on plane, the boat speed will prevent sucking in gravel and other debris off the bottom. The sucking is still acting, but the water intake passes over the bottom too quickly to allow debris to be lifted into the water intake.

While boating through shallow water areas, decide a course of travel that avoids sharp rocks and other underwater obstacles that could damage the boat. Running your boat through these areas on full plane may be helpful because the boat will be riding higher in the water. If the boat gets stuck on the bottom, immediately stop the engine and move the boat to deeper water.

onj1

### Water Intake Blockage

It is possible to lose power caused by suction holding flat stones, weeds, leaves, plastic, paper, or other debris against the water intake and restricting water flow. If you shut off the engine and wait a few seconds, the debris may fall off and full power will be restored. If, however, the debris trapped in the water intake grate, the engine will have to be shut off and the blockage will have to be pried out.

#### **WARNING**

**Avoid injury resulting from contacting the rotating impeller. Always shut off the engine before attempting to remove a blockage from the water intake.**

of

## OPERATION

ona1

### Clearing A Jammed Impeller

It is possible, for a stone or other debris inside the jet housing to lodge between the impeller and wall, especially after the engine has been stopped. This will lock the drive shaft and will prevent the engine from being able to crank over for starting. In this case follow these steps for freeing the jam.

Turn the ignition key or lanyard stop switch to the OFF position and remove all the spark plug leads to prevent the engine from accidentally starting. Remove the flywheel or rewind cover and rotate the engine flywheel counterclockwise. If this doesn't free the jammed impeller, it will be necessary to remove the six screws and water intake housing.

#### WARNING

**If the flywheel is rotated to free a jammed impeller, there is the possibility that the engine will crank over and start. To prevent this type of accidental engine starting and possible serious injury, always turn the ignition key or lanyard stop switch to the OFF position and remove all spark plug leads from the spark plugs.**

oni1

### Mooring Your Boat

When your boat is pulled onto a beach or tied to a dock where the up and down wave action may cause the water intake housing to dig into sand or other debris, be sure to tilt the jet drive out of water. Failure to do this may cause the water intake housing to fill with sand or other debris and could prevent the outboard from cranking over for starting.

onf3

### Operating In Freezing Temperatures

If there is a chance of ice forming on the water, the jet drive should be removed and drained completely of water. If ice should form at the water level inside the outboard drive shaft housing, it will block water flow to the engine causing possible damage. Do not start the engine until the ice is clear.

of

## OPERATION

onb4

### Operating At High Elevations

Operating your jet drive at an elevation higher than 2500 ft. (762 m) above sea level may require a carburetor jet change. This will reduce the normal performance loss experienced as a result of lack of oxygen causing an overly rich fuel mixture at high altitudes. Consult your dealer.

**IMPORTANT: To prevent serious damage to the engine caused by a lean fuel mixture, DO NOT operate your outboard (if the carburetor jets were changed for high altitude operation) at a lower altitude unless the carburetor jets are changed again to correspond to the new elevation.**

one2

### Operating In Salt Water Or Polluted Water

If you keep your boat moored in the water, always tilt the outboard so the water intake is completely out of water (except in freezing temperature) when not in use.

Wash down the outboard exterior and flush out the exhaust outlet of the jet drive with fresh water after each use. Each month, spray Quicksilver or Mercury Precision Corrosion Guard on external metal surfaces.

of

## OPERATION

ofd4

### Engine Break-in Procedure

#### CAUTION

Severe damage to the engine can result by not complying with the Engine Break-in Procedure.

#### ENGINE BREAK-IN FUEL MIXTURE

Use a 50:1 (2%) gasoline/oil mixture in the first tank of fuel. Use of this mixture combined with oil from the oil injection system will supply adequate lubrication during engine break-in.

#### ENGINE BREAK-IN PROCEDURE

Vary the throttle setting during the first hour of operation. During the first hour of operation, avoid remaining at a constant speed for more than two minutes and avoid sustained wide open throttle.

## OPERATION

gof98

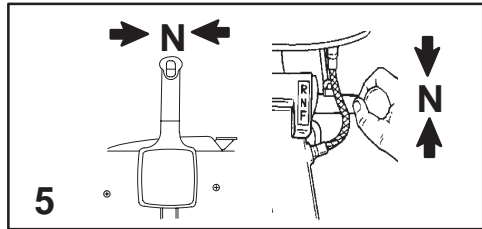
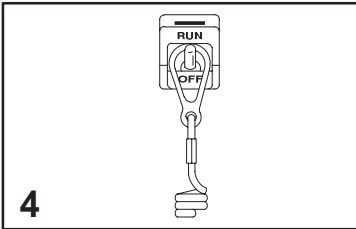
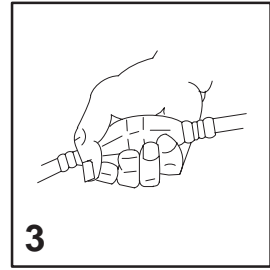
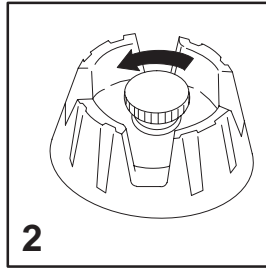
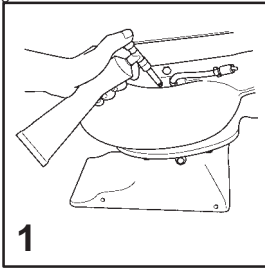

ofe18

### Starting The Engine

Before starting, read the Pre-Starting Check List, Operating Instructions, and Engine Break-in Procedure on the first eight pages in the Operation Section.

#### **⚠ CAUTION**

**Never start or run your outboard (even momentarily) without the water intake in the water to prevent damage to the water pump (running dry) or overheating of the engine.**

- 1 Make sure the drive shaft bearing on the jet drive is lubricated. Refer to Maintenance Section.
- 2 Open fuel tank vent screw (in filler cap) on manual venting type fuel tanks.
- 3 Squeeze the fuel line primer bulb several times until it feels firm.
- 4 Set the lanyard stop switch to RUN position. Read the Lanyard Stop Switch safety explanation and Warning in the General Information Section.
- 5 Shift outboard to neutral (N) position.

## OPERATION

gof58

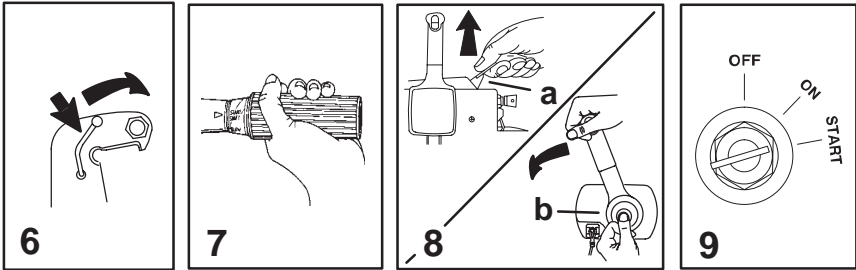

ofe47

### Starting The Engine – (Continued)

- 6** Models without power trim – Position the tilt lock lever to the Lock position.
- 7** Tiller Handle Models – Align the throttle grip pointer with START position.
- 8** Remote Control Models – **If engine is cold**, advance the fast idle speed lever (a) or throttle only feature (b) to an approximate halfway (1/2) setting. After engine start up, immediately adjust neutral fast idle setting so engine speed drops below 2000 RPM. Return back to normal idle speed after engine is warmed up.
- 9** Turn ignition key to START position and start the engine. **If engine is cold**, push in on key to prime the engine while cranking. If engine fails to start in ten seconds, wait 30 seconds and try again. If engine begins to stall, re-prime (push key in) until engine is running smoothly.

*NOTE: Starting Flooded Engine:*

**Remote Control Models** – Advance the fast idle speed lever or throttle only feature to the full maximum position. Without activating primer, crank engine for 10 seconds. Wait 30 seconds and repeat until engine starts. Immediately start to reduce engine speed after engine starts.

**Tiller Handle Models** – Advance the throttle grip to full throttle speed. Without activating primer, start engine following starting procedure. Immediately start to reduce engine speed after engine starts.

(continued on next page)

of

gof73

## OPERATION

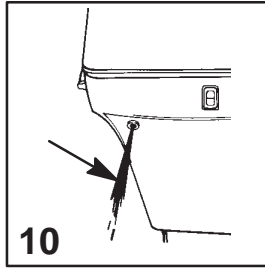

ofe12

### Starting The Engine (Continued)

**10** Check for a steady stream of water flowing out of the water pump indicator hole.

**IMPORTANT:** If no water is coming out of the water pump indicator hole, stop engine and check cooling water intake holes for obstruction. No obstruction may indicate a water pump failure or blockage in the cooling system. These conditions will cause the engine to overheat. Have the outboard checked by your dealer. Operating the engine while overheated will cause engine damage.

## OPERATION

gof60

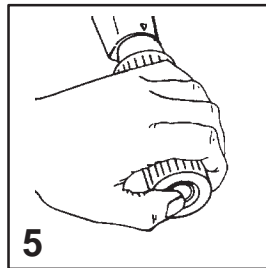
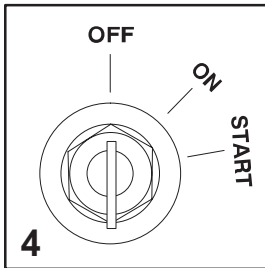
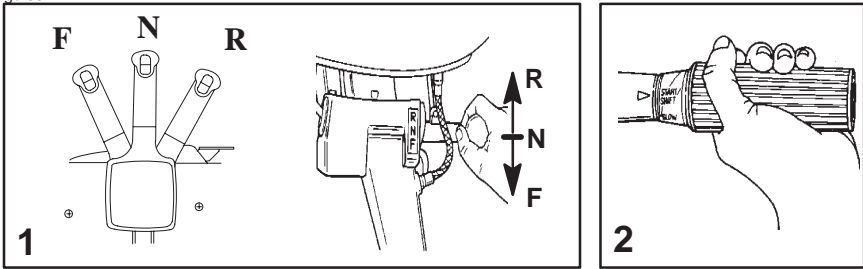

ofj8

### Gear Shifting

- 1 Your outboard has three gear shift positions to provide operation: Forward (F), Neutral (out of gear), and Reverse (R).
- 2 Tiller handle Models – Reduce engine speed to idle before shifting.
- 3 After shifting outboard into gear, advance the remote control lever or rotate the throttle grip (tiller handle models) further to increase speed.

ofm3

### Stopping The Engine

- 4 **Remote Control Models** – Reduce engine speed and shift outboard to neutral position. Turn ignition key to OFF position.
- 5 **Tiller Handle Models** – Reduce engine speed and shift outboard to neutral position. Push in the engine stop button or turn ignition key to OFF position.

## OPERATION

gof74

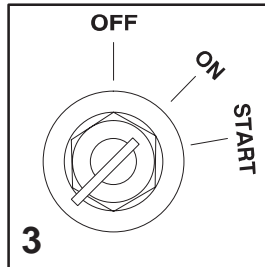
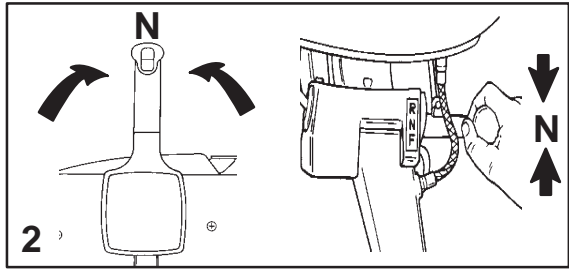
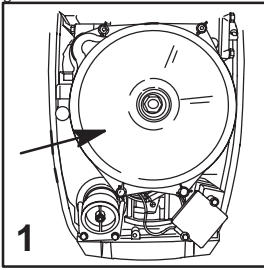

ofp8

### Emergency Starting

If the starter system fails, use the spare starter rope (provided) and follow procedure.

- 1 Remove flywheel cover.
- 2 Shift outboard to neutral (N) position.

### **⚠ WARNING**

When using emergency starter rope to start engine, the start-in-gear protection provided by the neutral interlock switch is inoperative. Make sure to set the outboard gear shift into neutral to prevent outboard from starting in gear. Sudden unexpected acceleration could result in serious injury or death.

- 3 Turn the ignition key to ON position.

## OPERATION

gof134

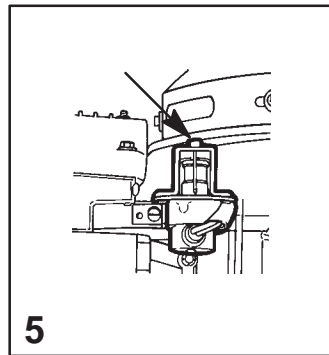
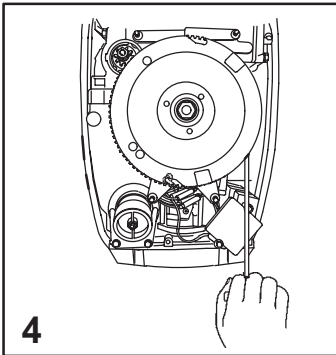

ofp11

### Emergency Starting

#### **⚠ WARNING**

To prevent getting an electrical shock, **DO NOT** touch any ignition component, wiring, or spark plug wire when starting or running the engine.

#### **⚠ WARNING**

The exposed moving flywheel can cause serious injury. Keep your hands, hair, clothing, tools, and other objects away from engine when starting or running the engine.

Do not attempt to reinstall the flywheel cover or top cowl when engine is running.

- 4** Place the starter rope knot into the flywheel notch and wind the rope clockwise around the flywheel.
- 5** If engine is cold, hold the fuel primer button in and pump up the fuel pressure with the fuel line primer bulb.
- 6** Pull the starter rope to start the engine.
- 7** After engine has started, do not reinstall the flywheel cover or top cowl.

# MAINTENANCE

oha4

## Outboard Care

To keep your outboard in the best operating condition, it is important that your outboard receive the periodic inspections and maintenance listed in the Inspection and Maintenance Schedule. We urge you to keep it maintained properly to ensure the safety of you and your passengers and retain its dependability.

### WARNING

**Neglected inspection and maintenance service of your outboard or attempting to perform maintenance or repair on your outboard if you are not familiar with the correct service and safety procedures could cause personal injury, death, or product failure.**

Record maintenance performed in Maintenance Log at the back of this book. Save all maintenance work orders and receipts.

## Selecting Replacement Parts For Your Outboard

We recommend using original Mercury Precision or Quicksilver replacement parts and Genuine Lubricants.

### WARNING

**Using a replacement part that is inferior to the original part could result in personal injury, death, or product failure.**

# MAINTENANCE

oti8

## EMISSION CERTIFICATION LABEL

An emission certification label, showing emission levels and engine specifications directly related to emissions, is placed on the engine at time of manufacture.

		EMISSION CONTROL INFORMATION	
This engine conforms to <input type="text"/> model year EPA regulations for Marine SI engines. Refer to Owner's Manual for required maintenance.			
<b>a</b>	IDLE SPEED: <input type="text"/>	FAMILY: <input type="text"/>	
<b>b</b>	<input type="text"/> hp	<input type="text"/> cc	FEL: <input type="text"/> g kWh
<b>c</b>	TIMING (IN DEGREES): <input type="text"/>		
<b>d</b>	Standard spark plug: <input type="text"/>	<input type="text"/>	
	Suppressor spark plug: <input type="text"/>		
	GAP: <input type="text"/>		
<b>e</b>	Valve Clearance (Cold) mm	Intake <input type="text"/>	Exhaust <input type="text"/>

- |  |  |
|--|--|
| <ul style="list-style-type: none"> <li>a - Idle Speed</li> <li>b - Engine Horsepower</li> <li>c - Timing Specification</li> <li>d - Recommended Spark Plug &amp; Gap</li> <li>e - Valve Clearance (if Applicable)</li> </ul> | <ul style="list-style-type: none"> <li>f - Family Number</li> <li>g - Maximum Emission Output for the Engine Family</li> <li>h - Piston Displacement</li> <li>i - Date of Manufacture</li> </ul> |
|--|--|

oti7

## OWNER RESPONSIBILITY

The owner/operator is required to have engine maintenance performed to maintain emission levels within prescribed certification standards.

The owner/operator is not to modify the engine in any manner that would alter the horsepower or allow emissions levels to exceed their predetermined factory specifications.

# MAINTENANCE

## Inspection And Maintenance Schedule

### BEFORE EACH USE

1. Check that lanyard stop switch stops the engine.
2. Visually inspect the fuel system for deterioration or leaks.
3. Check outboard for tightness on transom.
4. Check throttle, shift, and steering system for binding or loose components.
5. Make sure the drive shaft bearing on the jet drive is lubricated. (page 73)

### AFTER EACH USE AND AFTER EVERY 10 HOURS OF OPERATION

1. Lubricate the drive shaft bearing on the jet drive. (page 73)

### AFTER EACH USE

1. Flush out the outboard cooling system if operating in salt or polluted water. (page 61)
2. If operating in salt water, wash off all salt deposits and flush out the jet drive with fresh water.

### EVERY 100 HOURS OF USE OR ONCE YEARLY, WHICHEVER OCCURS FIRST

1. Lubricate all lubrication points. Lubricate more frequency when used in salt water. (page 73 and 74)
2. Inspect and clean spark plugs. (page 66)
3. Check engine fuel filter for contaminants. (page 63)
4. Adjust carburetors (if required).\*
5. Check engine timing setup.\*

(continued on next page)

\* *These items should be serviced by an authorized dealer.*

## **MAINTENANCE**

### **Inspection And Maintenance Schedule (Continued)**

#### **EVERY 100 HOURS OF USE OR ONCE YEARLY, WHICHEVER OCCURS FIRST**

1. Lubricate splines on the drive shaft.\*
2. Check corrosion control anode. Check more frequency when used in salt water. (page 65)
3. Check power trim fluid. (page 75)
4. Inspect battery. (page 62)
5. Check control cable adjustments.\*
6. Remove engine deposits with Quicksilver or Mercury PrecisionPower Tune Engine Cleaner.
7. Check tightness of bolts, nuts, and other fasteners.

#### **EVERY 300 HOURS OF USE OR THREE YEARS**

1. Replace water pump impeller (more often if overheating occurs or reduced water pressure is noted).\*

#### **BEFORE PERIODS OF STORAGE**

1. Refer to Storage procedure. (page 76)

\* *These items should be serviced by an authorized dealer.*

## MAINTENANCE

goh209

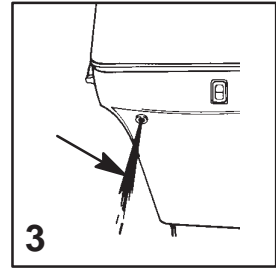
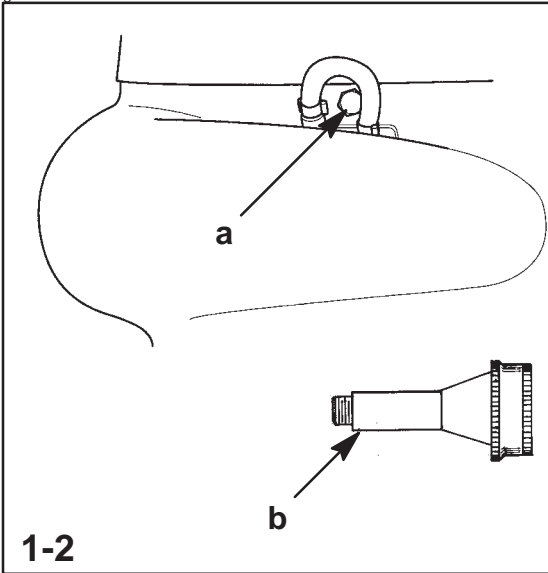

ohe7

### Flushing The Cooling System

Flush the internal water passages of the outboard with fresh water after each use in salt, polluted, or muddy water. This will help prevent a buildup of deposits from clogging the internal water passages.

Use Quicksilver or Mercury Precision accessory hose coupling Part Number 24789A1.

- 1** Remove plug and gasket (a) and thread-in hose coupling (b).
- 2** Attach a water hose to the hose coupling. Turn on the water gently, start the engine, and run it at idle speed only.
- 3** Check for a steady stream of water flowing out of the water pump indicator hole. Continue flushing the outboard for 3 to 5 minutes; adjust water pressure if needed.
- 4** Stop the engine, turn off the water, and remove the hose coupling. Reinstall the plug and gasket.

# MAINTENANCE

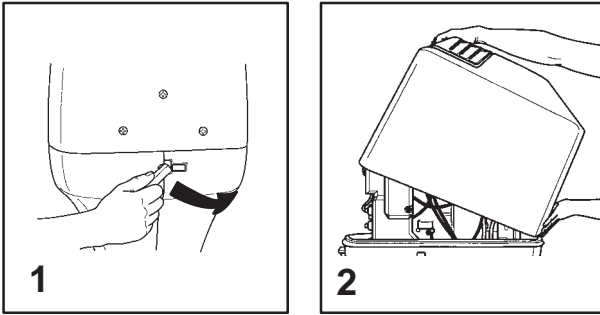

## Top Cowl Removal And Installation

### REMOVAL

- 1 Unlock the rear latch by pushing lever down.
- 2 Lift rear of cowl and disengage front hook.

### INSTALLATION

Engage the front hook and push cowl back over the cowl seal.  
 Push cowl down and move the rear latch lever up to lock.

## Battery Inspection

The battery should be inspected at periodic intervals to ensure proper engine starting capability.

**IMPORTANT:** Read the safety and maintenance instructions which accompany your battery.

1. Turn off the engine before servicing the battery.
2. Add water as necessary to keep the battery full.
3. Make sure the battery is secure against movement.
4. Battery cable terminals should be clean, tight, and correctly installed. Positive to positive and negative to negative.
5. Make sure the battery is equipped with a nonconductive shield to prevent accidental shorting of battery terminals.

## MAINTENANCE

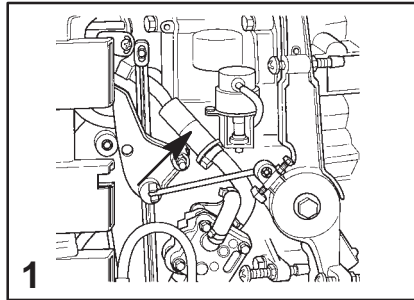

ohh1

### Fuel System

#### **⚠ WARNING**

**Avoid serious injury or death from gasoline fire or explosion. Carefully follow all fuel system service instructions. Always stop the engine. DO NOT smoke or allow open flames or sparks in the area while servicing any part of the fuel system.**

Before servicing any part of the fuel system, stop engine and disconnect the battery. Drain the fuel system completely. Use an approved container to collect and store fuel. Wipe up any spillage immediately. Material used to contain spillage must be disposed of in an approved receptacle. Any fuel system service must be performed in a well-ventilated area. Inspect any completed service work for sign of fuel leakage.

#### **FUEL LINE FILTER**

- 1** Inspect the fuel line filter. If the filter appears to be contaminated, remove and replace.

**IMPORTANT:** Visually inspect for fuel leakage from the filter connections by squeezing the primer bulb until firm, forcing fuel into the filter.

#### **FUEL LINE INSPECTION**

Visually inspect the fuel line and primer bulb for cracks, swelling, leaks, hardness, or other signs of deterioration or damage. If any of these conditions is found, the fuel line or primer bulb must be replaced.

## MAINTENANCE

goh103

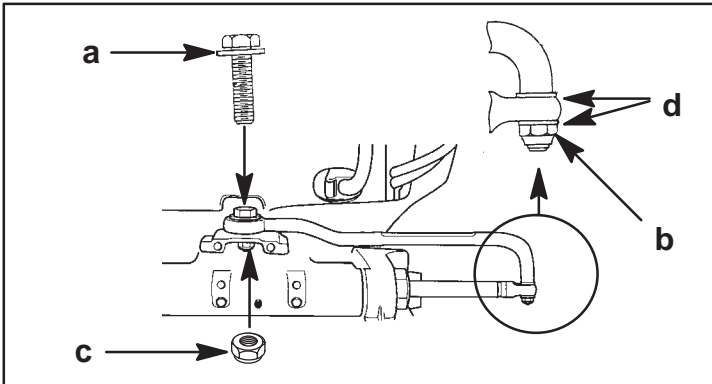

ohi1

### Steering Link Rod Fasteners

**IMPORTANT:** The steering link rod that connects the steering cable to the engine must be fastened using special washer head bolt (“a” – Part Number 10-14000) and self-locking nylon insert locknuts (“b” & “c” – Part Number 11-34863). These locknuts must never be replaced with common nuts (non locking) as they will work loose and vibrate off, freeing the link rod to disengage.

### **⚠ WARNING**

**Disengagement of a steering link rod can result in the boat taking a full, sudden, sharp turn. This potentially violent action can cause occupants to be thrown overboard exposing them to serious injury or death.**

Assemble steering link rod to steering cable with two flat washers (d) and self-locking nylon insert locknut (“b” – Part Number 11-34863). Tighten locknut (b) until it seats, then back nut off 1/4 turn.

Assemble steering link rod to engine with special washer head bolt (“a” – Part Number 10-14000) and self locking nylon insert locknut (“c” – Part Number 11-34863). First torque bolt (a) to 20 lb. ft. (27.1 N·m), then torque locknut (c) to 20 lb. ft. (27.1 N·m).

## MAINTENANCE

goh142

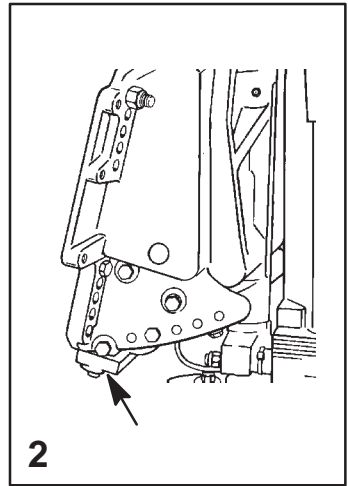
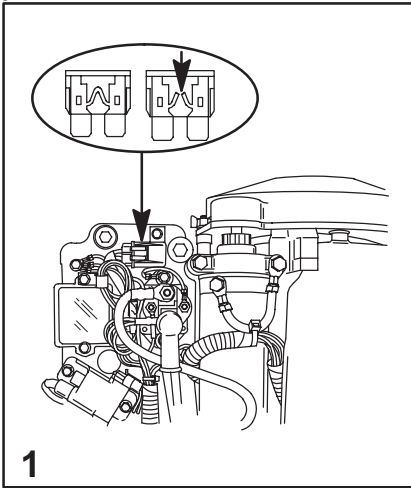

omh3

### Fuse Replacement

**IMPORTANT:** Always carry spare SFE 20 AMP fuses.

The electric starting circuit is protected from overload by an SFE 20 AMP fuse. If the fuse is blown, the electric starter motor will not operate. Try to locate and correct the cause of the overload. If the cause is not found, the fuse may blow again.

- 1 Open the fuse holder and look at the silver colored band inside the fuse. If band is broken, replace the fuse. Replace fuse with a new fuse with the same rating.

ohk4

### Corrosion Control Anode

Your outboard has a corrosion control anode installed on the bottom of the transom bracket assembly. An anode helps protect the outboard against galvanic corrosion by sacrificing its metal to be slowly eroded instead of the outboard metals.

- 2 The anode requires periodic inspection especially in salt water which will accelerate the erosion. To maintain this corrosion protection, always replace the anode before it is completely eroded. Never paint or apply a protective coating on the anode as this will reduce effectiveness of the anode.

## MAINTENANCE

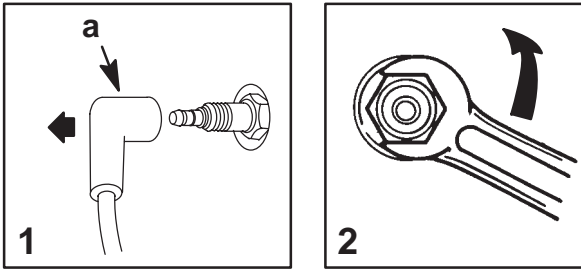

### Spark Plug Inspection and Replacement

#### **⚠ WARNING**

**Avoid serious injury or death from fire or explosion caused by damaged spark plug boots (a). Damaged spark plug boots can emit sparks. Sparks can ignite fuel vapors under the engine cowl. To avoid damaging spark plug boots, do not use any sharp object or metal tool such as pliers, screwdriver, etc. to remove spark plug boots.**

- 1** Remove the spark plug boots (a) by twisting the rubber boots slightly and pull off.
- 2** Remove the spark plugs to inspect. Replace spark plug if electrode is worn or the insulator is rough, cracked, broken, blistered or fouled.
- 3** Before installing spark plugs, clean away dirt on the spark plug seats. Install plugs finger tight, and tighten 1/4 turn or torque to 20 lb. ft. (27 N·m).

# MAINTENANCE

goh138

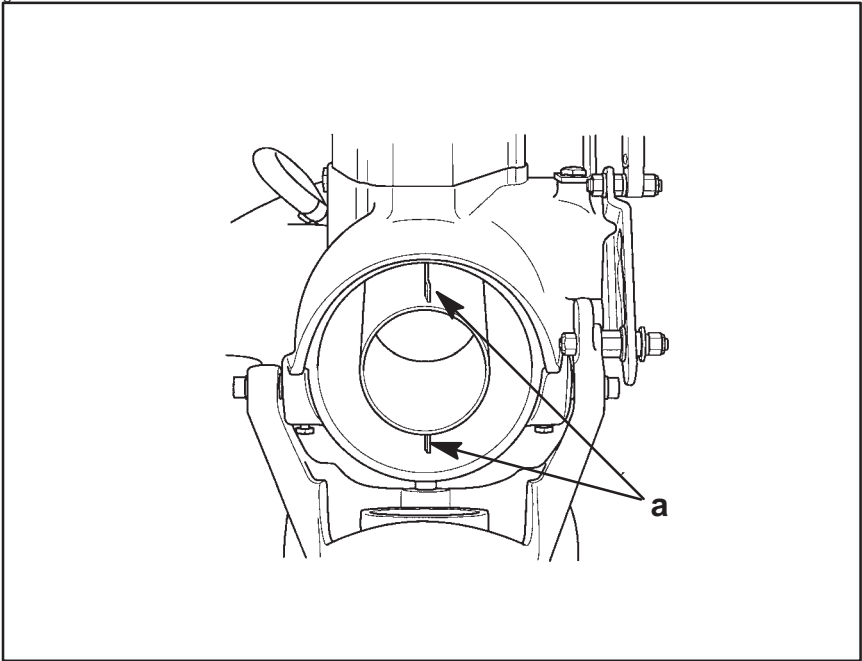

omq1

## Steering Pull Adjustment

The steering on some boats will have the tendency to pull towards starboard. This pulling condition can be corrected by using a pliers and bending the ends of the exhaust fins (a) 1/16 in. (1.5mm) toward the starboard side of the outboard.

# MAINTENANCE

goh128

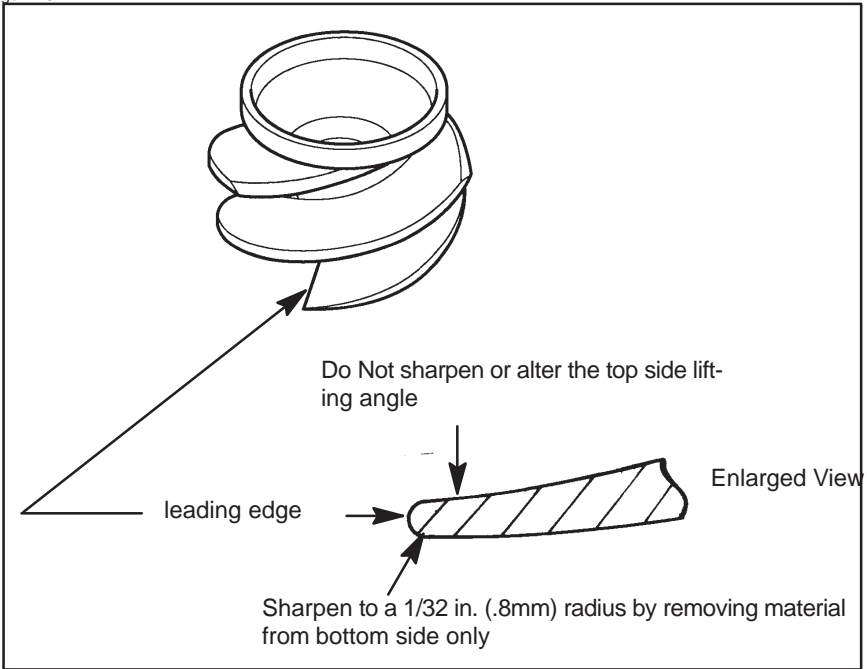

omm1

## Worn (Dull) Impeller

The intake of gravel through the pump can round off and wear the leading edges on the impeller. Some conditions you may experience from a worn impeller are, (1) a noticeable performance loss, especially on acceleration, (2) difficulty getting the boat on plane, or (3) an increase in engine RPM at wide open throttle. Check the impeller blades occasionally for damage. Use a flat file to resharpen the leading edges as shown.

## MAINTENANCE

goh129

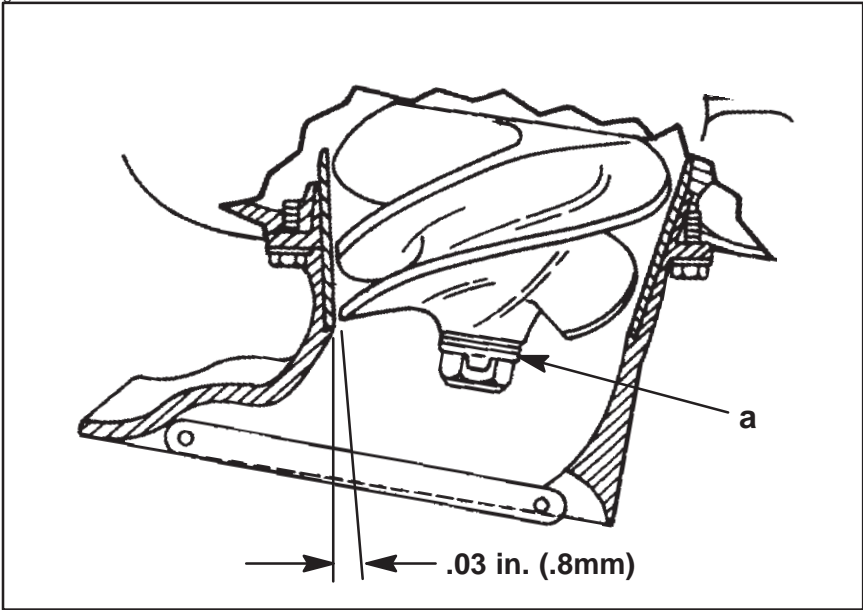

omn1

### Impeller Clearance Adjustment

The impeller should be adjusted so there is approximately .03 in. (.8mm) clearance between the impeller edge and liner. Operating your jet drive in waters that contain sand and gravel can cause wear to the impeller blades, and the clearance will start to exceed .03 in. (.8mm). As the blades wear, shims (a) located in the stack outside of the impeller can be transferred behind the impeller. This will move the impeller further down into the tapered liner to reduce the clearance.

Check the impeller clearance by sliding a feeler gauge through the intake grate and measure the clearance between the impeller edge and liner. If adjustment is required, refer to Impeller Removal and Installation in this Maintenance Section.

# MAINTENANCE

goh139

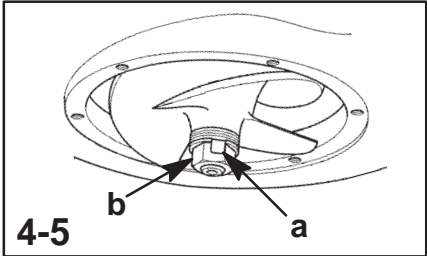
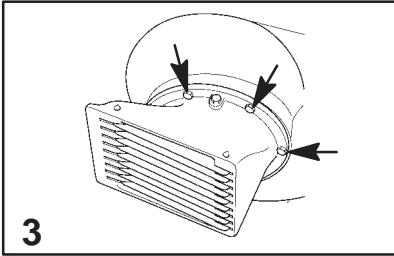
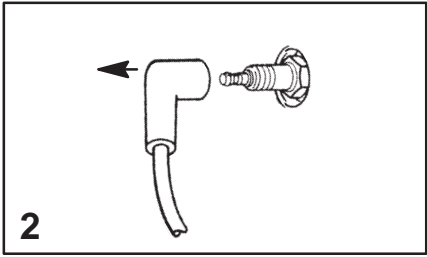
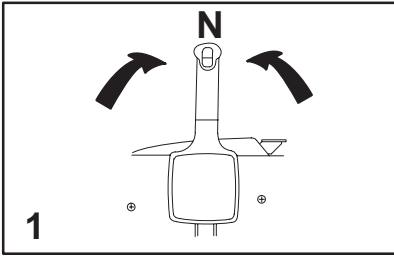

omo1

## Impeller Removal And Installation

### **⚠ WARNING**

If the drive shaft is rotated while the engine is in gear, there is the possibility that the engine will crank over and start. To prevent this type of accidental engine starting and possible serious injury caused from being struck by a rotating impeller, always shift outboard to neutral position and remove spark plug leads when you are servicing the propeller.

### REMOVAL

- 1** Shift outboard to neutral (N) position.
- 2** Remove spark plug leads to prevent engine from starting.
- 3** Remove the water intake housing that is fastened with six screws.
- 4** Straighten the bent tabs (a) on the impeller nut retainer and remove the impeller nut (b).
- 5** Pull impeller straight off the shaft. If the impeller is tight, use a hammer and block of wood to rotate the impeller (clockwise) on the shaft until the keyway is directly above the flat on the shaft. This will free the jammed key and allow removal.

# MAINTENANCE

goh131

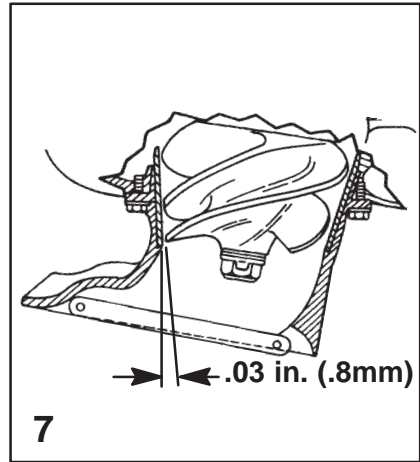
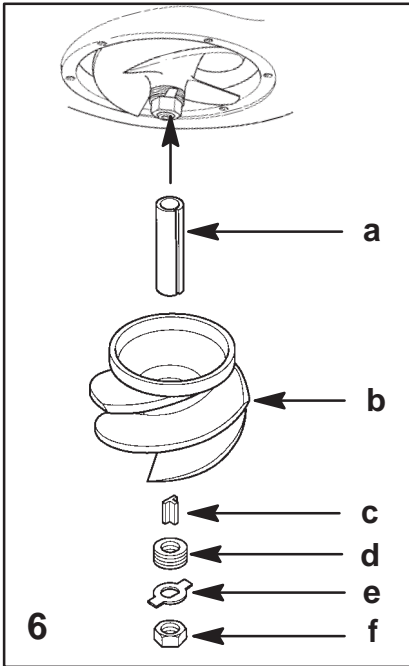

omo2

## Impeller Removal And Installation

### INSTALLATION

- 6** Grease the drive shaft, shear key, and impeller bore. Place the plastic sleeve (a) inside the impeller (b) and install impeller, shear key (c), shims (d) nut retainer (e), and impeller nut (f). Turn the nut tight on the shaft to remove any play between the impeller and shaft. If the tabs on the retainer do not line up with the flats on the nut, remove the nut and turn the retainer over and re-tighten the nut again.
- 7** Temporarily reinstall the water intake housing in order to check for impeller clearance. The clearance between the impeller and liner should be .030 in. (.8 mm). Shim washers can be transferred to either side of the impeller to raise or lower the impeller to the correct clearance setting. The water intake housing can be shifted side ways a small amount in order to center the liner.

## MAINTENANCE

goh132

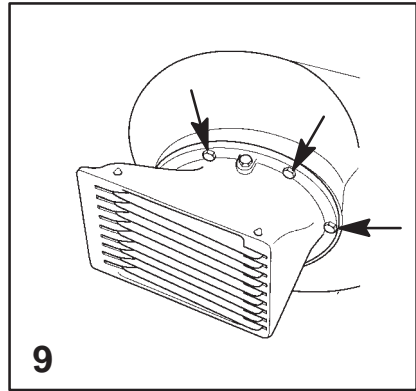
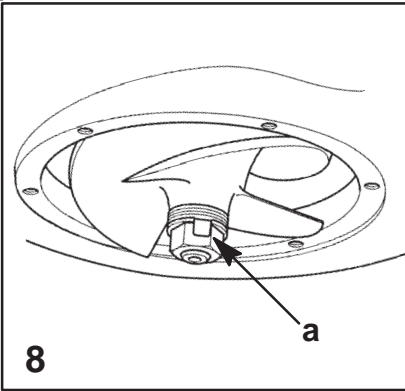

omo3

### Impeller Removal And Installation

#### INSTALLATION (CONTINUED)

- 8** After setting the impeller height, tighten the impeller nut snug with a wrench. Secure impeller nut by bending tabs (a) against the flats on the impeller nut.

*NOTE: If the outboard is used in salt water, apply Quicksilver or Mercury Precision Anti-Corrosion Grease around the entire mounting flange on the water intake housing and also to the threads on the six mounting bolts.*

- 9** Reinstall the water intake housing with six bolts. Check clearance around the impeller to make sure the water intake housing is centered and not rubbing against the liner. Torque mounting bolts to 120 lbs. in. (13 N·m).

# MAINTENANCE

goh133

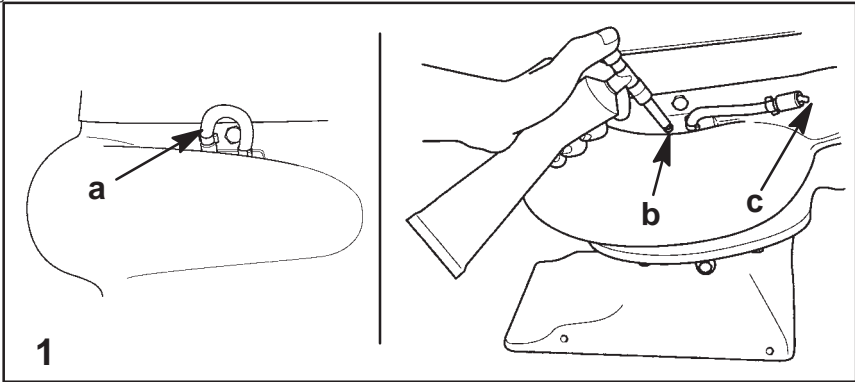

oh33

## Lubrication Points

### 1 Lubricating the drive shaft bearing.

**Recommended Lubrication** - Use Quicksilver or Mercury Precision 2-4-C Marine Lubricant with Teflon, or Lubriplate 630-AA Grease.

**IMPORTANT:** It is important that you do not use a general-all-purpose grease for this bearing. The lubricant we recommend is a water resistant grease of the proper consistency for this application. If you use a substitute grease, be sure that it is water resistant and of the same consistency.

**Frequency of lubrication** - We recommend lubricating the drive shaft bearing after each day's use and after every 10 hours of operation. After every 30 hours of operation, pump in extra grease to purge out any moisture.

**Lubricating Procedure** - Pull vent hose (a) off the grease fitting. Pump in grease (b) through the grease fitting (using the grease gun provided) until excess grease starts to exit the vent hose (c).

Reconnect the vent hose (a) onto the grease fitting after greasing.

After 30 hours of operation, pump in extra grease to purge out any moisture. Visually inspecting the purged grease at this time will give you an indication of conditions inside the bearing housing. A gradual increase in moisture content, indicates seal wear. If the grease begins to turn dark, dirty gray, the drive shaft bearing and seals should be inspected and replaced if necessary. Some discoloration of the grease is normal during the break-in period on a new set of seals.

## MAINTENANCE

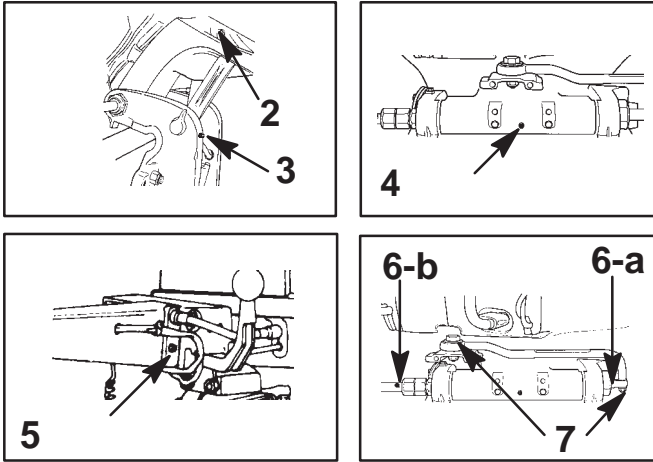

oho19

### Lubrication Points

Lubricate Points 2 thru 6 with Quicksilver or Mercury Precision Lubricants 2-4-C Marine Lubricant with Teflon or Special Lubricate 101.

- 2** Swivel Bracket – Lubricate through fitting.
- 3** Tilt Support lever – Lubricate through fitting.
- 4** Tilt Tube – Lubricate through fitting.
- 5** Tiller Handle – Lubricate through fitting.
- 6** Steering Cable Grease Fitting (If Equipped) – Rotate steering wheel to fully retract the steering cable end (a) into the outboard tilt tube. Lubricate through fitting (b).

### **⚠ WARNING**

The end of the steering cable must be fully retracted into the outboard tilt tube before adding lubricant. Adding lubricant to steering cable when fully extended could cause steering cable to become hydraulically locked. An hydraulically locked steering cable will cause loss of steering control, possibly resulting in serious injury or death.

Lubricate Points 7 With Light Weight Oil.

- 7** Steering Link Rod Pivot Points – Lubricate pivot points.

## MAINTENANCE

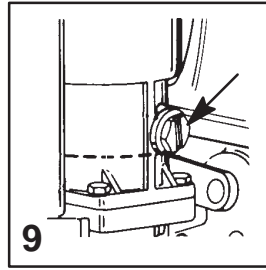
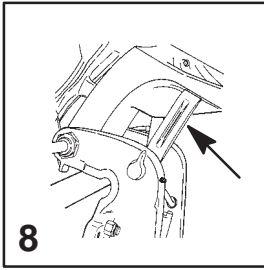

### Checking Power Trim Fluid

- 8** Tilt outboard to the full up position and engage the tilt support lock.
- 9** Remove fill cap and check fluid level. The fluid level should be even with the bottom of the fill hole. Add Quicksilver or Mercury Precision Lubricants Power Trim & Steering Fluid. If not available, use automotive (ATF) automatic transmission fluid.

### Submerged Outboard

A submerged outboard will require service within a few hours by an authorized dealer once the outboard is recovered from the water. This immediate attention by a servicing dealer is necessary once the engine is exposed to the atmosphere to minimize internal corrosion damage to the engine.

# STORAGE

oia2

## Storage Preparation

The major consideration in preparing your outboard for storage is to protect it from rust, corrosion, and damage caused by freezing of trapped water.

The following storage procedures should be followed to prepare your outboard for out of season storage or prolonged storage (two months or longer).

oib11

## FUEL SYSTEM

**IMPORTANT: Gasoline containing alcohol (ethanol or methanol) can cause a formation of acid during storage and can damage the fuel system. If the gasoline being used contains alcohol, it is advisable to drain as much of the remaining gasoline as possible from the fuel tank, remote fuel line, and engine fuel system.**

Fill the fuel system (tank, hoses, fuel pump, and carburetors) with treated (stabilized) fuel to help prevent formation of varnish and gum. Proceed with following instructions.

1. Portable Fuel Tank – Pour the required amount of gasoline stabilizer (follow instructions on container) into fuel tank. Tip fuel tank back and forth to mix stabilizer with the fuel.
2. Permanently Installed Fuel Tank – Pour the required amount of gasoline stabilizer (follow instructions on container) into a separate container and mix with approximately one quart (one liter) of gasoline. Pour this mixture into fuel tank.
3. Place the outboard in water or connect flushing attachment for circulating cooling water. Run the engine for ten minutes to allow treated fuel to reach the carburetors.

## STORAGE

### PROTECTING EXTERNAL OUTBOARD COMPONENTS

4. Lubricate all outboard components listed in the Inspection and Maintenance Schedule.
5. Touch up any paint nicks. See your dealer for touch-up paint.
6. Spray Quicksilver or Mercury Precision Lubricants Corrosion Guard on external metal surfaces (except corrosion control anodes).

### PROTECTING INTERNAL ENGINE COMPONENTS

*NOTE: Before performing Steps 7 and 8, make sure the fuel system has been prepared for storage. Refer to Fuel System on previous page.*

7. Place the outboard in water or connect flushing attachment for circulating cooling water. Start the engine and let it run in neutral to warm up.
8. With engine running at fast idle, stop the fuel flow by disconnecting the remote fuel line. When engine begins to stall, quickly spray Quicksilver or Mercury Precision Storage Seal into carburetors until engine stops from lack of fuel.
9. Remove the spark plugs and inject a five second spray of Quicksilver or Mercury Precision Storage Seal around the inside of each cylinder.
10. Rotate the flywheel manually several times to distribute the storage seal in the cylinders. Reinstall spark plugs.

### JET DRIVE

11. Pump extra grease into the jet drive bearing to purge out moisture.

## **STORAGE**

### **POSITIONING OUTBOARD FOR STORAGE**

Store outboard in an upright (vertical) position to allow water to drain out of outboard.

### **BATTERY STORAGE**

1. Follow the battery manufacturers instructions for storage and recharging.
2. Remove the battery from the boat and check water level. Recharge if necessary.
3. Store the battery in a cool, dry place.
4. Periodically check the water level and recharge the battery during storage.

# TROUBLESHOOTING

## **1 – STARTER MOTOR WILL NOT CRANK THE ENGINE**

### **POSSIBLE CAUSES**

- Remote control models – Blown 20 Amp fuse in the starting circuit. Refer to Maintenance Section.
- Outboard is not shifted to neutral position.
- Weak battery or battery connections are loose or corroded.
- Ignition key switch failure.
- Wiring or electrical connection faulty.
- Starter motor or starter solenoid failure.

## **2 – ENGINE WILL NOT START**

### **POSSIBLE CAUSES**

- Lanyard stop switch not in RUN position.
- Incorrect starting procedure. Refer to Operating Section.
- Old or contaminated gasoline.
- Engine flooded. Refer to Operating Section.
- Fuel is not reaching the engine.
  - a. Fuel tank is empty.
  - b. Fuel tank vent not open or restricted.
  - c. Fuel line is disconnected or kinked.
  - d. Primer bulb not squeezed.
  - e. Primer bulb check valve is faulty.
  - f. Fuel filter is obstructed. Refer to Maintenance Section.
  - g. Fuel pump failure.
  - h. Fuel tank filter obstructed.
- Ignition system component failure.
- Spark plugs fouled or defective. Refer to Maintenance Section.

## **TROUBLESHOOTING**

### **3 – ENGINE RUNS ERRATICALLY**

#### **POSSIBLE CAUSES**

- Spark plugs fouled or defective. Refer to Maintenance Section.
- Incorrect setup and adjustments.
- Fuel is being restricted to the engine.
  - a. Engine Fuel filter is obstructed. Refer to Maintenance Section.
  - b. Fuel tank filter obstructed.
  - c. Stuck anti-siphon valve located on permanently built in type fuel tanks.
  - d. Fuel line is kinked or pinched.
- Fuel pump failure.
- Ignition system component failure.

### **4 – ENGINE OVER-SPEED (EXCESSIVE RPM)**

#### **POSSIBLE CAUSES**

- Outboard mounted too high on the transom.
- Worn jet pump impeller or liner.
- Incorrect jet pump impeller clearance adjustment.
- Tilting the outboard out beyond a vertical position.
- Cavitation of the impeller due to rough water or obstruction in the boat hull.

### **5 – BATTERY WILL NOT HOLD CHARGE**

#### **POSSIBLE CAUSES**

- Battery connections are loose or corroded.
- Low electrolyte level in battery.
- Worn out or inefficient battery.
- Excessive use of electrical accessories.
- Defective rectifier, alternator, or voltage regulator.

# OWNER SERVICE ASSISTANCE

or6

## **Local Repair Service**

Always return your outboard to your local authorized dealer should the need for service arise. Only he has the factory-trained mechanics, knowledge, special tools and equipment and the genuine parts and accessories to properly service your engine should the need occur. He knows your engine best.

or2

## **Service Away From Home**

If you are away from your local dealer and the need arises for service, contact the nearest authorized dealer. Refer to the Yellow Pages of the telephone directory. If, for any reason, you cannot obtain service, contact the nearest Mercury Marine Service Office.

or7

## **Parts And Accessories Inquiries**

All inquiries concerning genuine replacement parts and accessories should be directed to your local authorized dealer. The dealer has the necessary information to order parts and accessories for you. When inquiring on parts and accessories, the dealer requires the model and serial number to order the correct parts.

# OWNER SERVICE ASSISTANCE

or4

## Service Assistance

Your satisfaction with your outboard product is very important to your dealer and to us. If you ever have a problem, question or concern about your outboard product, contact your dealer or any Authorized Mercury Marine Dealership. If additional assistance is required, take these steps.

**1.** *Talk with the dealership's sales manager or service manager. If this has already been done, then contact the owner of the dealership.*

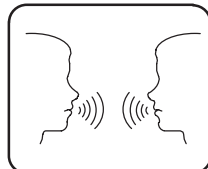

**2.** *Should you have a question, concern or problem that cannot be resolved by your dealership, please contact Mercury Marine Service Office for assistance. Mercury Marine will work with you and your dealership to resolve all problems.*

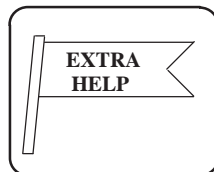

The following information will be needed by the service office:

- Your name and address
- Daytime telephone number
- Model and serial number of your outboard
- The name and address of your dealership
- Nature of problem

Mercury Marine Service Offices are listed on the next page.

# OWNER SERVICE ASSISTANCE

or5

## Mercury Marine Service Offices

For assistance, call, fax, or write. *Please include your daytime telephone number with mail and fax correspondence.*

 Telephone	 Fax	 Mail
<b>United States</b>		
(920) 929-5040	(920) 929-5893	Mercury Marine W6250 W. Pioneer Road P.O. Box 1939 Fond du Lac, WI 54936-1939
<b>Canada</b>		
(905) 567-6372	(905) 567-8515	Mercury Marine Ltd. 2395 Meadowpine Blvd. Mississauga, Ontario Canada L5N 7W6
<b>Australia, Pacific</b>		
(61) (3) 9791-5822	(61) (3) 9793-5880	Mercury Marine Australia 132-140 Frankston Road Dandenong, Victoria 3164 Australia
<b>Europe, Middle East, Africa</b>		
(32) (87) 32 • 32 • 11	(32) (87) 31 • 19 • 65	Marine Power - Europe, Inc. Parc Industriel de Petit-Rechain B-4800 Verviers Belgium
<b>Mexico, Central America, South America, Caribbean</b>		
(305) 385-9585	(305) 385-5507	Mercury Marine - Latin America & Caribbean 9010 S.W. 137th Ave. Suite 226 Miami, FL 33186 U.S.A.
<b>Japan</b>		
81-53-423-2500	81-53-423-2510	Mercury Marine - Japan 283-1 Anshin-cho Hamamatsu, Shizuoka, 435-0005 Japan
<b>Asia, Singapore</b>		
5466160	5467789	Mercury Marine Singapore 72 Loyang Way Singapore 508762



